

# THE ARUP JOURNAL

MAY 1967



# THE ARUP JOURNAL

---

Vol. 1. No. 3 Published May 1967 by  
Ove Arup & Partners Consulting Engineers  
13 Fitzroy Street, London W1

---

Editor: Rosemary Devine  
Art Editor: Desmond Wyeth

---

## Contents

Reproduced on the front cover - by permission of the Botswana High Commissioner in London - is the postage stamp issued to celebrate the independence of Botswana in 1966 and shows the National Assembly Building referred to in Eric Walker's article; the back cover shows a detail of the same building.

- 2 BOTSWANA  
Eric Walker
- 6 CARDBOARD FORMERS FOR HOLLOW VOID SLABS  
R. B. Taylor
- 10 SUSPENDED FRAME BUILDINGS AND IN PARTICULAR  
THE STANDARD BANK CENTRE  
D. Michael and  
J. M. D. Anderson

---

## Botswana

Eric Walker

Most people will probably have to look at a map to find where Botswana is. It is a large country of about 230,000 square miles, lying to the north-west of South Africa and bounded on the other sides by South West Africa, Angola and Rhodesia. There is a short boundary with Zambia on the Zambezi River in the north.

Botswana became a British Protectorate at the end of the nineteenth century at the request of the Paramount Chief (grandfather of the present President, Sir Seretse Khama) to Queen Victoria to prevent Botswana being occupied either by Cecil Rhodes and his colleagues or the Afrikaner Republics of the Transvaal and the Orange Free State. Although the name appears to have been changed when Independence was granted on 30 September, 1966, it is really only the return to the original name. When the first missionaries arrived in Botswana, they asked some of the locals the name of the place and were told 'Botswana', so they wrote down 'Bechuana'. It was known as the British Bechuanaland Protectorate until Independence.

As one of the British High Commission Territories, not incorporated in the Union of South Africa in 1908, the country has always used and still uses South African currency and has a customs union with South Africa. The railway to Bulawayo comes through Botswana from Mafeking and is owned and operated by Rhodesia Railways. It was for many years Rhodesia's only outlet to the south and the railway followed the road taken by the early pioneers coming north in the days of the ox wagons.

### THE IMPERIAL RESERVE

Bechuanaland was administered from Mafeking just across the border in the Cape Province. A piece of land was set aside there when the Union was formed. It belonged to the British Government and enjoyed the splendid name of 'The Imperial Reserve'. When South Africa left the Commonwealth and it appeared that Bechuanaland would become independent, it became inconvenient to have the capital in a foreign country, and so it was decided to build a new capital in Bechuanaland. Many people thought this should have been at Francistown, some 120 miles south of Bulawayo, which although a very small town, was the largest in the territory.

### GABERONES

Botswana is largely desert and the rainfall is very low. The water position was better at Gaberones than at most places. The area was crown land and not part of any tribal territory, so that tribal jealousies would not be provoked. So Gaberones, named after a local chief, was chosen as the site.

The small village contained little more than two stores, a quite appalling hotel and one or two government offices.

### THE NEW CAPITAL

The building of a new capital for a new nation in a dry, somewhat uninteresting piece of the world, with very little money and little hope of private investment, was a formidable task and the final result, now nearly completed, is a great credit to everybody concerned. To be quite honest, we got our first job in the new Gaberones Capital Project when a commercial reinforcing firm in Bulawayo decided to go out of business and invited us to take over their uncompleted projects.

### GABERONES SECONDARY SCHOOL

Our first job was a secondary school and we came into the picture when the scheme was thought out but nothing had been drawn. The architects' drawings were finished so there was little alternative but to make the thing work. The money available had to go even further than in most jobs and the resulting scheme is stark and functional. We all tried to make something of the building by very careful detailing so that at least it would have the polish which a highly detailed job has. Everything was meticulously thought out to fit in with brick courses but our efforts were frustrated when the contractor put an unarguable case for using concrete blocks instead of bricks for everything but external faces of walls.

The school is mostly single storey with the exception of the classroom blocks, which are double storeyed. All building materials, except sand and stone, were transported from either Rhodesia or South Africa. Most came from Rhodesia because transport by rail was cheaper. The suspended floors over the classrooms are hollow block construction.

### SEROWE SCHOOL

We have been commissioned to do another identical school at Serowe, the capital of the Bamangwato, whose chief is Sir Seretse Khama. This school has not yet been built because the money has not been found. We have modified the scheme by substituting solid concrete slabs 8 in. thick and have saved about £1,000. Serowe is thirty miles from the nearest station at Palapye on a rather indifferent sand road, and the cost of transporting hollow blocks by rail and then by road did not seem to make sense.



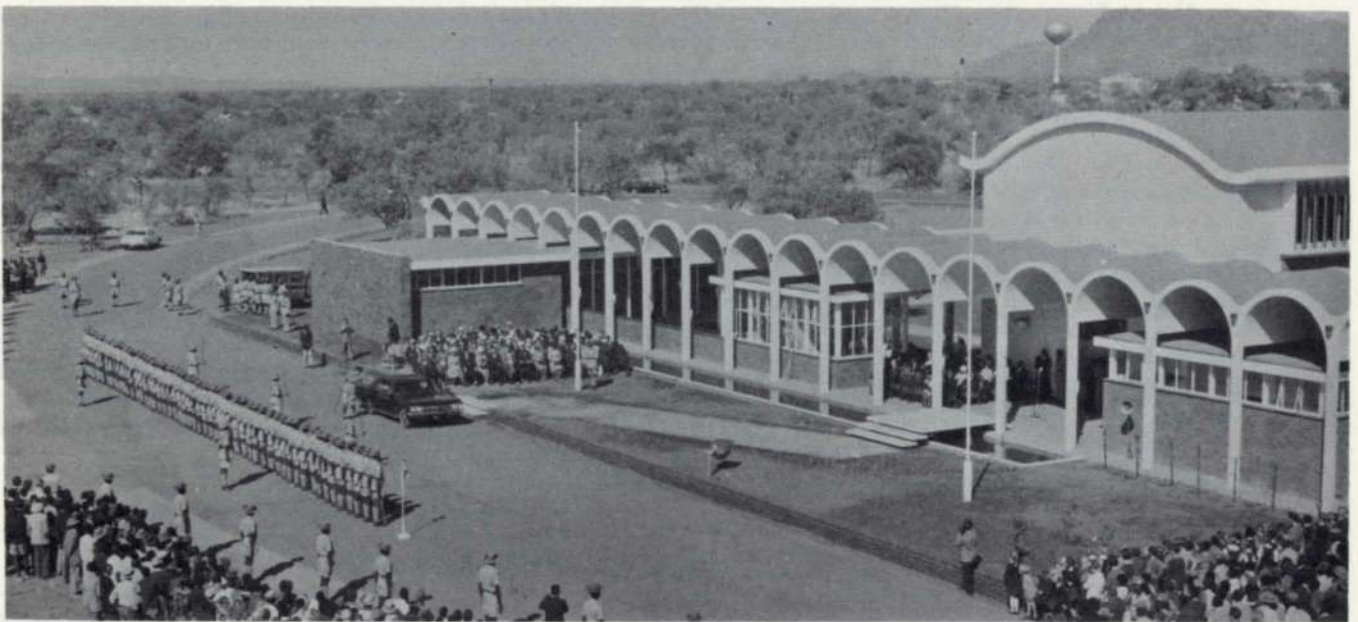

Fig. 1  
The National Assembly Building, Gaborone

#### COLLAPSING SAND

Much of Botswana is covered by Kalahari or collapsing sand, which is a soil type occurring in the western part of Rhodesia and up past the Victoria Falls and Lusaka to the Copperbelt. It is a windblown formation, consisting of clay and sand particles lightly deposited with the clay holding the sand grains apart. When wet and under pressure the clay particles disintegrate allowing the sand grains to come into contact with each other and the whole material literally collapses. The material is deceptive because it is hard to tell if it is collapsing unless you have had previous experience of it. Excavations stand with their sides perfectly vertical. The answer in most cases is to get through the collapsing sand and found on something stable underneath and this is the approach we used on all our work at Gaborone. We provided columns and bases, supporting ground beams, and the depth varied from 4 ft. to 12 ft. The collapsing sand is capable of supporting normal surface beds.

#### OTHER FOUNDATIONS

There was also expansive clay in the Gaborone area but we never hit it on any of our sites. In Serowe the problem is different because the school will be on a bit of exposed and not very decomposed basalt. The problem will be to get the foundations under ground level. In Francistown, where we hope to do another job, the problem is almost the same. There is about 6 in. to 1 ft. of sandy top soil and then granite.

#### OTHER GABERONES JOBS

We also did the Central Police Station in Gaborone, which was a straight-forward two-storey concrete frame and the Prime Minister's house, which is a fairly big double storey residence with brick load-bearing walls. Her Majesty's Commissioner's Office provided some drama as provision for an additional floor was required after first floor level had been concreted. The office crystal ball was used to reassess the foundation pressure. All these buildings had the same meticulous brick course details and were built mainly in concrete blocks.

#### THE NATIONAL ASSEMBLY BUILDING

This is the only building where there was a reasonable budget as the Bechuanaland Government wanted it to be the focal point of the new capital and of independent Botswana. The Council Chamber is covered by a shell 80 ft. long with a span of 35 ft. and a rise of 7 ft. The thickness at the crown is 3½ in. This went very well and various problems anticipated due to sophisticated structures in remote places did not materialize. The concrete aggregate was flaky and variable dolerite. The only quarry had a take-it-or-

leave-it approach, so we had the aggregate divided into two size ranges and used a proportion of each with great success.

I spent the day on top of the shuttering during the first pour and apart from getting very sunburned, everything went without a hitch.

The 18 smaller shells in the colonnade provided problems. No longitudinal restraint could be provided, and the architect very much wanted the columns to taper to 3 in. wide at the base. On the other hand, I have a letter on the file saying 'unless some alteration is made the partners will not accept responsibility'. I am not unused to being crushed in the middle but in this case the pressures were so great that in a wilder moment I nearly contemplated a private U.D.I. Like most intractable problems it was solved, and the result is very elegant - I think.

The usual argument about back shuttering arose with the contractors. We told them they could back shutter or concrete but not both. A trial shutter was made and concreted and everything went smoothly from then on. London office were much involved in these shells and such things as drawings coming by sea when the wind was blowing the wrong way, or drawings rolled and flattened, kept us all on our toes. We always iron our clothes in the printing machine, so creased drawings were no problem. It was decided to put a balcony on each side of the Chamber, cantilevered off the columns, after building had started, and this introduced some horrible reactions. It was solved by tying the bases together at ground floor level. In theory, the Opposition could drop the roof on the Government by cutting the ties in the floor with a hack saw.

The Members' Wing is quite different as it is steel-framed and the co-ordination between architectural and structural detailing is very precise. The steel structure erected alone reminded me of a half-built ship, but we are very proud of the finished building, and many details worked out for this will be used again.

The co-operation with London was excellent and much of the correspondence entertaining. It is a pity that all those who helped cannot see and enjoy the finished building. There are copper masks on the rain-water spouts on the front of the colonnade and I once thought that each person who helped could be commemorated by having a gargoyle in his likeness.

For the independence celebrations a new set of stamps was issued and our National Assembly Building is illustrated



on the 2½ cent denomination. It is a good picture of the building but we feel that the green trees in the background are probably what the artist would like the place to look like because we do not remember seeing them.

#### SOUTH AFRICAN INFILTRATION

During the course of our work in Gaborones, Rhodesia became more politically unacceptable to the British Government than South Africa had been, and I think for this reason a certain amount of the work started going to South African architects. We like to think it was because of the good impression we had made from this end that our South African office got involved in several projects, including the Town Hall and an Agricultural Demonstrators' College.

#### INDEPENDENCE STADIUM

We were then asked by the Bechuanaland National Sports Council to design a grandstand for Independence Stadium. The money was to be raised by appeals throughout the world and from the profits from football matches to be played in the stadium. The Council thought that they could raise about £6,000. Due to pressure of work in Bulawayo we asked London to do some initial thinking and two alternatives were sent to us. We had previously done a grandstand on a shoestring in Bulawayo and we tried the same principle and to our surprise found that it was cheaper than the schemes from London. We investigated precasting and prestressing the rakers on the ground but this was quite uneconomic as there was no prestressing equipment nor lifting gear available. A structural steel alternative was also much more expensive.

The finished stand cost just under £6,000 and seats 1007 people and has an area for V.I.P.s. in the centre. The centre section is roofed and this can be extended over the whole stand when money is available. The stand shell can be extended either way in multiples of 11 ft. 9 in., if the profits from football are satisfactory.

There is inverted box rib sheeting underneath the stand to deflect rain and bottles dropped by spectators. This was cheaper than providing risers to all treads and we had had trouble previously on another grandstand with water penetration where we had precast concrete risers and treads. It provides a ready-made roof for the changing rooms etc. which the Council hope to build underneath in future.

I was quite horrified to hear that the Council had decided that the stand should be painted in the Botswana national colours of black, blue and white, but the finished result is really quite nice, and all the top brass watched Bechuanaland becoming Botswana from our grandstand on a rather windy night.

#### VIBRATIONS

We cut the structure to the bone economically and there was a certain amount of apprehension in Gaborones because vibration could be felt on the top of the stand if one leaped about. We thought that this was mostly psychological and would not have been noticed on a steel structure. The effect on spectators of climbing up the stand and then looking over the top and finding themselves with no visible means of support was quite alarming and one gentleman had to be assisted down having climbed up on his own. When the stand is full of spectators, this vibration is damped out, but, like every other grandstand we have done, the calculations were checked three times and then once more just to make sure that everything was right, even if everybody on board danced on the cantilever.

#### GRANDSTAND SPECIALISTS

The latest development is that the Swaziland Government have seen our stand and seem impressed by it. We have been asked to give them information on providing a design for a similar stand. If this comes off, we shall probably make the rakers slightly deeper to get rid of the vibration - not that it is unsafe, but if people think it is, then it is.

It seems rather ironic that the Bulawayo office should become specialists in grandstands for independent countries.

#### THE OLYMPIC POOL

We were tremendously excited when we got an enquiry from the Bechuanaland National Sports Council about an Olympic size swimming pool and diving pool, and although we ascertained that the Olympic Games would not be held in Africa again this century, we did some preliminary investigation with great enthusiasm. We were quite sure that they did not know what size an Olympic pool was, and our report to them convinced them that they did not want an Olympic pool. I think it is very possible that they will want what we call a standard school swimming pool fairly soon and we have a cheap way of doing these which does not leak. At the moment we are doing a scheme for a small pool for the Khama family.

#### TEACHERS' TRAINING COLLEGE, FRANCISTOWN

We have done a lot of work on a Teachers' Training College at Francistown. The Assembly Hall has a rather interesting octagonal folded concrete roof, spanning about 70 ft. The money has not come for this yet but everybody has high hopes of its arrival soon.

#### GETTING THERE

Getting to Gaborones is always interesting. There is now an air service from Bulawayo but it is intermittent and of recent origin. It is about 400 miles by road through Botswana over rather poor surfaces and one is liable to be completely sunk in the soft sand at certain times of the year.

#### IT IS SLOWER BY RAIL

The most civilized way of travelling is by train but unfortunately the mail trains never seem to arrive or leave Gaborones except within an hour each side of midnight. The train journey can be monotonous because the country is flat and covered with thorn bush and seems to go on the same mile after mile. Every station looks the same except for the name but an enforced period of inactivity like this is good for the soul and allows one to catch up with one's thinking. I always felt terribly sorry for the kind individuals who met me off the train some time after midnight. I had often been in the dining car, keeping myself awake and my hosts had been performing a similar exercise in their homes. This usually resulted in nobody getting to bed very promptly. On one memorable occasion we arrived at a station fifty miles from Gaborones when a shunter erupted into the dining car and said in a broad South African accent, 'There has been an accident'. As we had thought we were about to arrive at Gaborones, we had made no provision for bedding on the train and my architect colleague and I spent a most uncomfortable night. The Railways in Gaborones did not know where their train was and our unfortunate host stayed at the station till nearly 3 o'clock and then went home. Had he known where the train was, he could have collected us in under an hour. Having spent nearly 11 hours in this delightful spot called Artesia, I can highly recommend it to anyone who does not want to go on a holiday anywhere.

On another occasion while sitting in the buffet car, observing life, I almost took cover under the table when a large florid bar steward announced in a loud Irish voice, 'There are too many Protestants at the bar'. To avoid staying up till midnight I usually came back on a mixed goods and passenger train, carrying mostly third and fourth class passengers. It stops at every halt from Gaborones to Bulawayo, and takes an enormously long time to get there. There is usually one first class carriage on the back and a very small buffet car. Most of the artisans, working on the Capital Project, were employed by Costains and came from Salisbury and I seemed often to get on the Thursday afternoon train, which was taking them back to Salisbury for their weekend of civilization. Celebrations started at Gaborones station and by the time the train had left, I must have been the only passenger who was not paralytic. Celebrations carried on for quite some time on





Fig. 2  
Independence Stadium, Botswana

the train and silence suddenly descended about 10 o'clock. It was a very second-hand looking contingent that alighted at Bulawayo station the next morning.

When we reached the halt before the Botswana/Rhodesian border many African passengers climbed off with their luggage on their heads and disappeared into the bush. It was much easier than going through customs and immigration.

#### THE ROAD TO SEROWE

I had to go to Serowe to look at the foundations for the school and took my daughter with me for company. She had imagined that the roads would be like our Rhodesian main roads, which are capable of speeds as fast as your car can go, and that Serowe would be like one of our smaller towns. The road was sandy most of the way and Serowe is the biggest African settlement I think I have ever seen. It seems to spread for miles and consists of hundreds of rondavels and goat and cattle kraals. There seemed to be practically no movement and no men; where they were, I do not know. We called on the District Commissioner who seemed a relic from imperial days. I expected to be welcomed like Stanley meeting Livingstone but was told off for not making an appointment.

On this day we managed to cover 541 miles, which is reasonably good going on gravel and sand roads.

#### THE ROAD TO GABERONES

At the Rhodes and Founders Holiday in July I took my whole family to Gaborone as we had often been invited. We went south by road into South Africa and when we got level with Gaborone turned west. We could not get accurate information about the border posts but arrived at a likely one, or so we thought, called Derdepoort. Here we suddenly ran on to a small piece of tar and into a most efficient South African Police post. The constable inside was extremely polite but very surprised to see us and said, 'God, man, you don't want to go through'. We said that we did. At this moment my daughter ran in from outside and said, 'You can't go through here, there is no road on the other side'. We looked through the barrier and sure enough there were two wheel tracks with long grass growing between them

going up the hill. The border posts shut at four o'clock and it was now half past three. The most helpful constable directed us to the next post, nearer Gaborone, and said that he would radio his colleague there and tell him that we were coming so that he could hold the post open. To our delight, he was called Koos and we suspect that his surname was van der Merwe. Our friend said that he had told a white lie in that he had told Koos that we were lost. We assured him that it was no lie.

#### THE FUTURE

We met very many charming and dedicated people in Botswana, who are doing their utmost to make the country succeed. It is a very poor country of some 500,000 inhabitants and which has suffered from droughts for many years. In many places the average rainfall is only about 12 in. and a drought can be pretty drastic. Many of the civil servants are moving on. Many are expatriate Scots - most Scots are. They do not want to return to Britain and are finding it increasingly more difficult to find a place in the diminishing colonial Empire, where they have worked all their lives. It was even suggested that the name should be Scotswana.

This country deserves to succeed - in fact, must. It has the advantage that the President is not only the tribal leader but also the elected political leader; but has the disadvantages of a poor, often starving people, and an erratic rainfall that has amounted to a drought for years past.

I often wonder if independence is right for Botswana yet, because an independent country should be able to stand on its own without outside financial assistance, and Botswana certainly cannot do that for some time to come. Perhaps independence is fashionable and Botswana has been forced to go along with the stream.

It was not all work. In a small way I helped to start a thriving Round Table in Gaborone and it should be chartered soon.

Botswana's two neighbours, South Africa and Rhodesia, are the obvious sources of financial and technical help in the future and one can only hope that Botswana in her new-found independence finds herself in a position to accept that help.



# Cardboard formers for hollow void slabs

R.B. Taylor

## SYNOPSIS

This article covers three aspects of cardboard formers - their development, their application and a comparison with other former types.

**DEVELOPMENT** A brief history of the evolution of cardboard formers is given going back to 1950.

**APPLICATION** The formers were used in the University of Exeter Physics Building designed by Sir Basil Spence, Bonnington and Collins and an outline is given of the reasoning that led to their use. Various aspects of their use on site are discussed - former assembly, handling, re-use of insets, tolerances, durability and fire hazard.

**COMPARISON** Similar formers are available in steel, glass fibre and timber and cardboard is compared with these rivals.

## DEVELOPMENT

For many years cardboard has been a great success as a container. Its main function was the prevention of the contents from bursting out and little regard was paid to

rigidity. A concrete former not only has to be rigid but also has to be able to withstand the effects of a shower of rain and wet concrete. It is not surprising that it took some time to develop a cardboard that was able to do the job. One of the earliest attempts to produce a cardboard former in this country was in 1950 when experiments were carried out on a building in Bristol. Unfortunately the attempts failed because of difficulties relating to cardboard strength. Some ten years later, research in this country was stimulated by the knowledge that the Americans had produced a feasible former. Cardboard manufacturers experimented with various treatments but it was a breakthrough in a completely different field which helped to solve the problem. On the east coast of Scotland the fishing industry distributed their catch in containers in which the fish were mixed with an equal proportion of ice. The containers had to retain their shape for at least 24 hours and the board produced to do this job was ideal for the manufacture of formers.

As far as can be established the first building in which cardboard formers were used successfully in this country was the present offices of Robinson Building Techniques in Bristol. They were used here for seven of the thirteen floors and it was claimed that an additional saving of between £18,000 and £25,000 could have been made if the formers had been used for the other six floors as well.

## APPLICATION AT EXETER

The preliminary design for Exeter University Physics Building was being carried out by Ted Happold's group in 1960. The solution involved both one-way and two-way hollow void slabs, so a method was sought which would provide voids that could easily and cheaply be varied in size. Cardboard boxes seemed to have possibilities -

Fig. 1 below

One-way spanning formers  
being prepared for concreting

Fig. 2 right

Exeter University Physics Building,  
Tower block, showing hollow void  
slabs prior to fin erection  
Photo: E. Happold





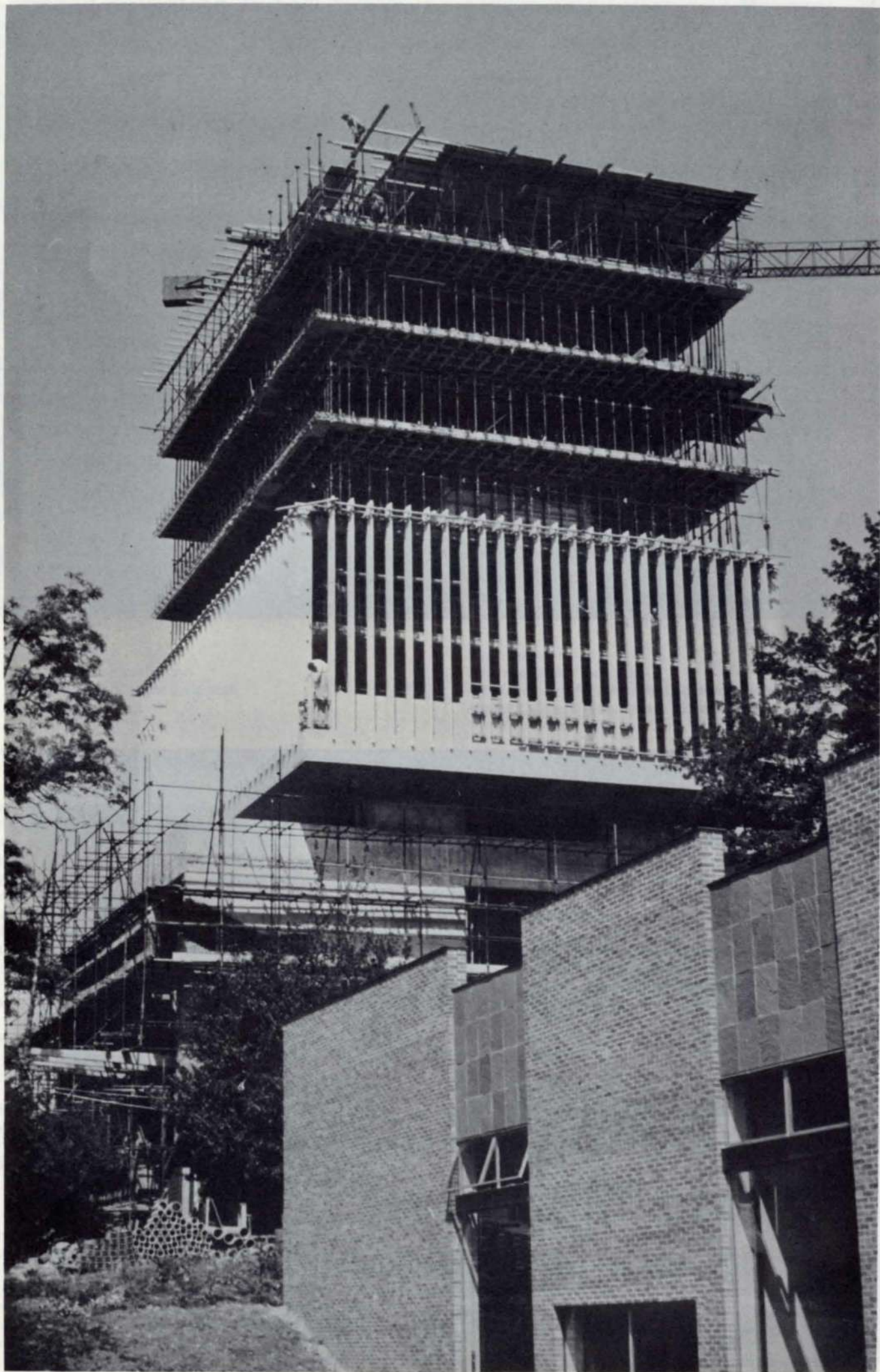



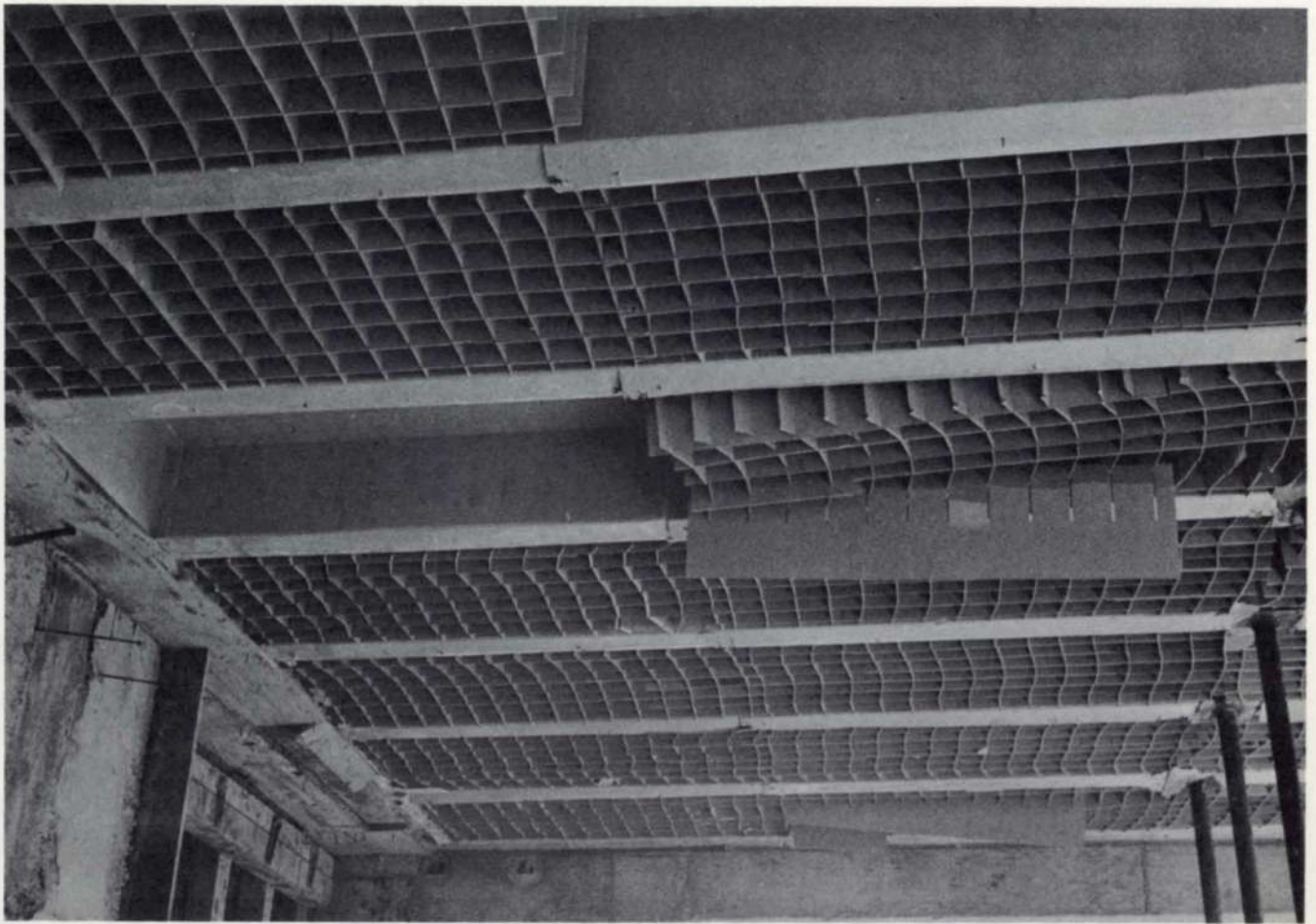

Fig. 3  
One-way slab from below  
after removal of soffit formwork

the manufacturers would, in fact, accept orders in increments of 1/16 in. between the range of about 6 in. x 6 in. x 10 in. and 18 in. x 20 in. x 30 in. We became involved in a dialogue with Hygrade Box Co. Ltd., one of the largest box manufacturers in the world, to see whether they could treat their standard cardboard boxes with wax so that they could be used as formers. This would have meant setting up a hand waxing machine but they were quite willing to do this.

We then discovered that Robinson Building Techniques were interested in cardboard formers and were proposing to use them on their new building in Bristol. Robinsons went into it in a big way and tried out a large number of different methods of treating the cardboard. We felt that the decision to use these formers must lie with the contractor. So we wrote in the bills of quantities that the contractor should consider their use and enclosed a performance specification to help him get quotations. The successful contractor, E.G.M. Cape Ltd., thought that it was a good idea and decided to use them. The price that they submitted for the two-way former (void size 9 in. x 19 in. x 20 in.) was 7/- and for the one-way former (void 9 in. x 20 in.) was 9/6 per linear yard.

#### SLAB CONSTRUCTION

The rigidity of the former was provided by an egg crate type of insert over which was folded a pre-creased cardboard cover. The cover was then stapled on to the deck. This provided a rigid enough former to allow steel fixers and concreters to move around in their usual manner. A poker vibrator was used in the ribs with no adverse effects on the cardboard and finally a tamping board was used to compact and finish the 2½ in. topping.

#### HANDLING

The inserts and covers fold flat and being also extremely light in weight, everything required for a bay could be taken up in one lift. For the same reasons storage space was no problem and in fact when the formers were delivered on site doubt was expressed as to whether a large enough quantity had been sent. The disadvantage was that these folded units had to be assembled but this required no skill and did not take a great deal of time. Some of this time was saved by not having to worry about mould oil (also eliminating trouble with debonding of reinforcement). There was also a possible hidden advantage in the fact that cardboard was a new material in this application and so more care might have been taken over construction. However the former's greatest feature was its disposable nature. No recovery of former was required.

#### RE-USE

The actual cover can only be used once but the manufacturers claim that the inserts can be used again. However, at Exeter the contractor has not been able to do this to any great extent and the one-way spanning insets in particular seem unable to survive double usage.

#### DURABILITY

At one stage in the contract a bay of one-way formers was laid out in position for a week before concreting took place. During this time they were subjected to rain as well as the usual traffic of site workers - eventually a tarpaulin was thrown over them. When concreting was able to take place it was surprising how few had to be repaired. It was believed on site that two-way formers would have survived the test.



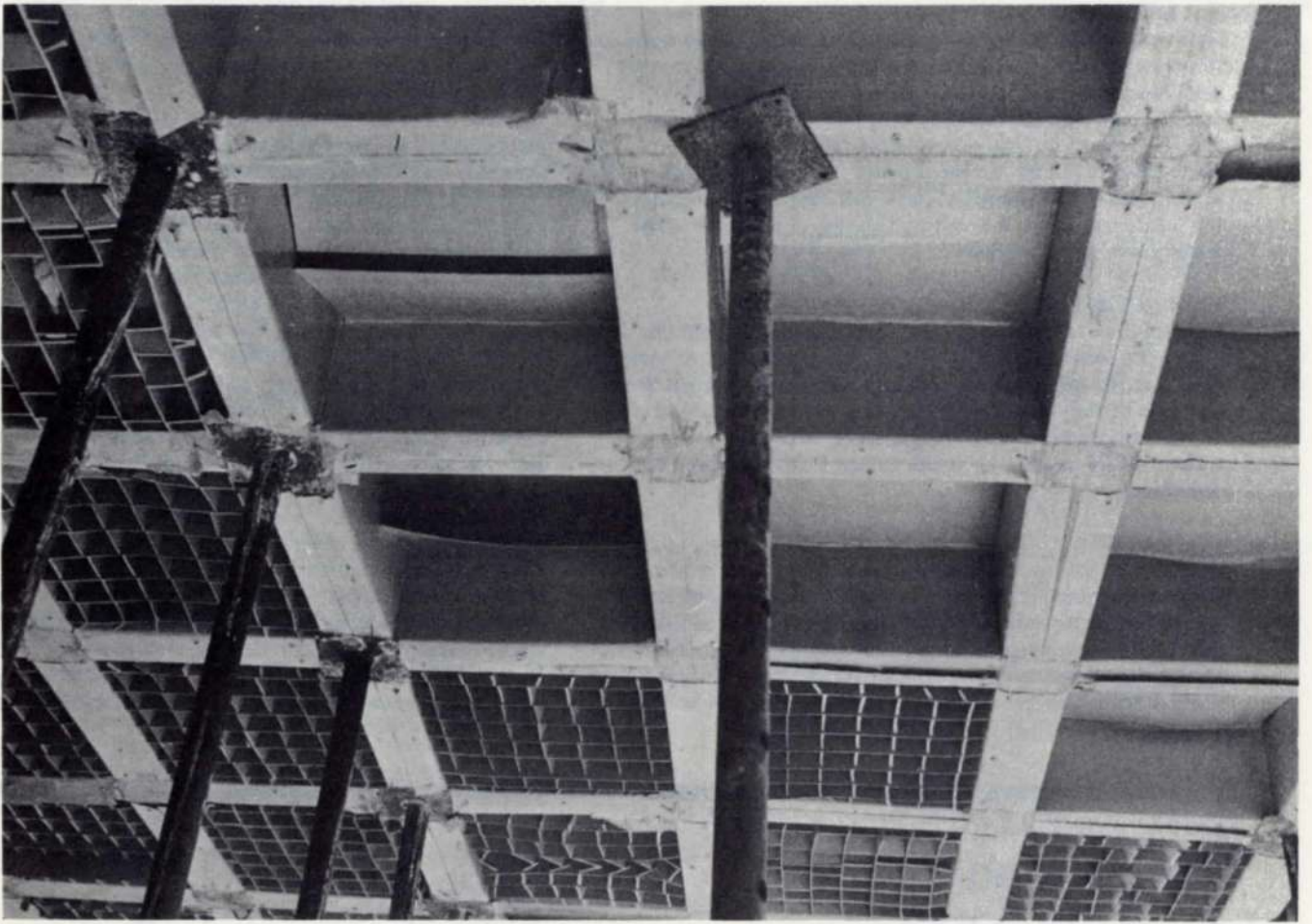
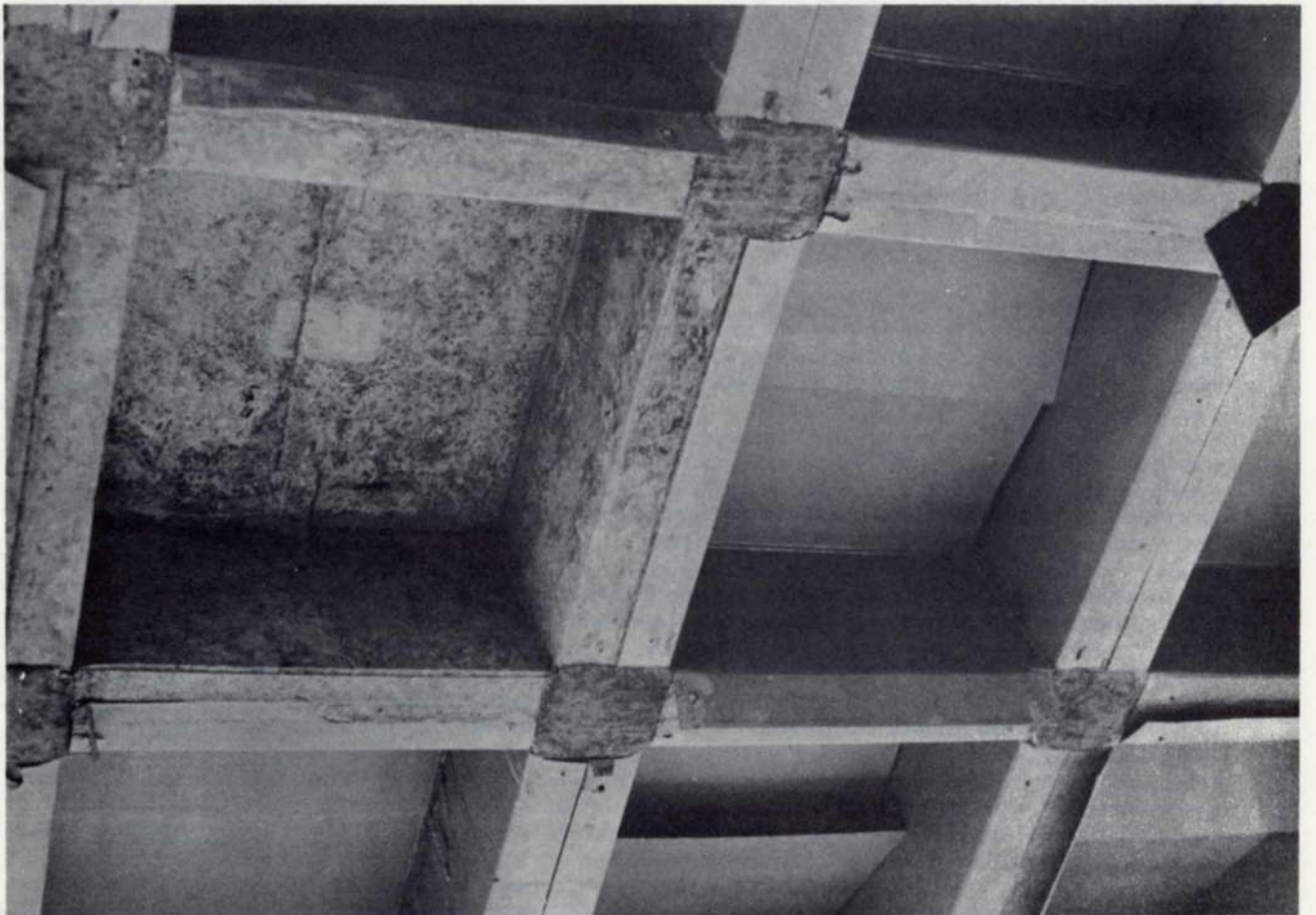

Fig. 4 above  
Two-way slab from below  
after removal of soffit formwork

Fig. 5 below  
Two-way hollow void slab  
with cardboard former removed  
Photo: E. Happold





#### TOLERANCES

An inspection of the two-way slab from below shows quite an impressive pattern of uniformity. The box-shaped former used here is by nature much more able to withstand deformation than the one-way system. One tends to find that the ribs in the one-way system have bulged or contracted in places but the amount is of no structural significance. Occasionally there has been a leak at one of the joints but due to the cellular nature of the inserts the leaks were very localized.

#### FIRE RATING

The practice of leaving the formers in place is liable to worry the local authority from a fire hazard point of view. It is possible to cover the formers with a foil to make them conform to the Government fire regulations but they are so easily removed that this should not be necessary. At Exeter a fire-proof suspended ceiling has eliminated any objections.

#### COMPARISON

Formers of this type are also available in steel, glass fibre and timber. They are designed for re-use and hence any comparison with cardboard depends on their ability to survive in a reasonable shape, the ease with which they can be withdrawn and the ease of handling on site. Unfortunately claims regarding re-usage vary considerably and so it is

difficult to come to any definite conclusions. Some contractors have claimed over twenty repeats from glass fibre while others have only managed three. The same seems to apply to steel.

Tapered sides and compressed air inlet nozzles have been incorporated in their designs to facilitate recovery and yet even this has been proved unsatisfactory in some cases. One would imagine that the mould oils used by the successful contractors and those used by the unsuccessful do not vary considerably. Nor should the concrete used cause any appreciable difference in the coefficient of friction between mould and slab. A variable of probably far greater significance is the depth of the voids and the distance between ribs. Shallow voids with ribs at relatively large centres will obviously give rise to easy recovery. There is a timber former available which falls under this category (4 in. wide and 5 in. deep ribs at 24 in. centres) and it is apparently competing well against cardboard. One field in which cardboard formers could possibly be excluded is exposed slabs. The finish could not compete with fibre glass or steel.

Until more information is available it is going to be difficult to make any definite conclusions, except that if one suspects that difficulty is going to be experienced in recovery, cardboard formers are a safe bet. They have worked well in the Exeter Physics Building and even the contractor's Canadian site engineer has murmured his admiration for them.

## Suspended frame buildings and in particular the Standard Bank Centre

D. Michael and  
J.M.D. Anderson

This paper  
will be discussed  
at the June  
Technical Staff Meeting.  
Everyone is  
welcome to attend

#### INTRODUCTION

We define the suspended frame building as a multistorey block whose facade structure carries the floor loads upwards to some cross structure and then down through a core to the foundations.

Since the structural frame is a relatively large part of its cost one normally minimizes the amount of structure in a building. This, in turn, will imply transferring floor loads to the nearest column and thence directly to the foundations. Other design requirements often conflict with this minimization of the structure. We are adjusted to utilizing large horizontal spans, where some amenity justifies the cost. Equally one may carry the loads through a devious vertical route to achieve some amenity, and this is the *raison d'être* of the suspended frame in building.

#### EXISTING SUSPENDED FRAME BUILDINGS

About a dozen suspended frame buildings have been or are being built. Their features are summarized in Table 1. The typical example is a multi-storey office block, square in plan, with a heavy central service core, and the facade structure carrying the weight of the floors to a massive cantilever structure at roof level.

They are all 'quality' office blocks, but many reasons for

Fig. 1  
Standard Bank Centre  
Johannesburg  
Elevation

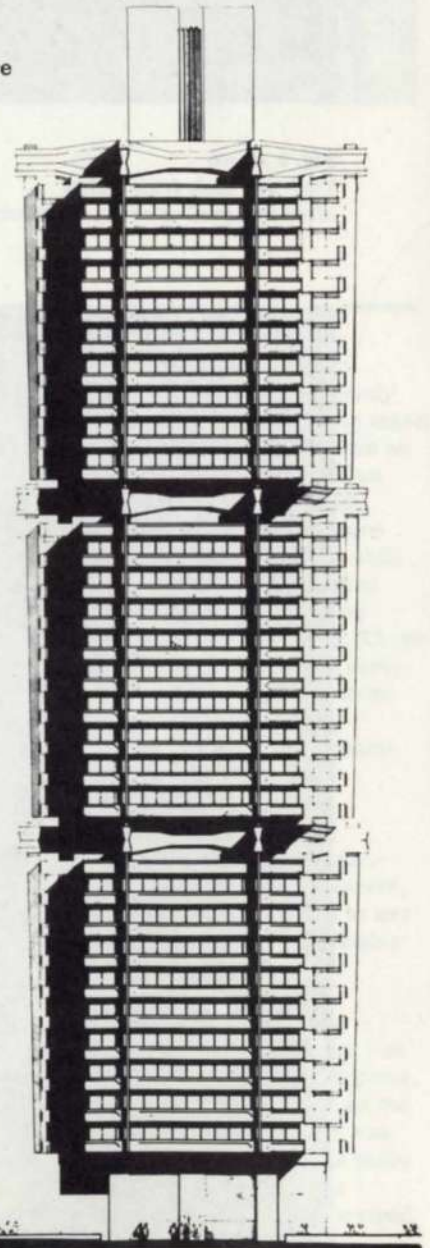



using a cantilever structure are claimed. The most valid reason seems to be that the great potential value of the ground level, for its amenity, its rent or its access, should not be compromised by the vertical members of the superstructure.

In the structural frames, the service cores are almost all reinforced concrete boxes. The cantilever structures have been girders, trusses and boxes, in steel and prestressed concrete. Again the hangers have been steel and prestressed concrete, but in many cases extensions were a controlling factor. Floors were made for minimum weight rather than minimum depth. Their most common feature is that these 12 buildings have been designed in the last six years but no obvious technological factor marks the occasion.

#### STANDARD BANK BUILDING - PLANNING

The Standard Bank Centre is a 459 ft. high office block in one corner of a 200 ft. square plot on Fox Street, Johannesburg. The design of this development has been produced by the joint architects, Hentrich, Mallows, Stucke, Harrison, Ritchie and Partners. The 30 typical floors are 112.5 ft. square in plan, with notched corners, round a central service core. This core extends above general roof level for a further four floors. The ground level is an open plaza with entrances to the tower and basements, and a ramp to the car parks. The five basements, each 200 ft. squares, extend to a depth of 60 ft.

Of the typical floors, 27 are for use as offices, being fully air conditioned with soundproof partitions and a double depth of rooms. Every tenth floor is a plant room, particularly for ventilation equipment. The air ducts run down the four re-entrant corners and feed off through holes in the floor ribs. Under the tower block, the ground slab is omitted to expose the banking hall in the lower ground floor. This space is enclosed with full height glazing suspended from the first floor. Also on the lower ground floor are public shops and a restaurant.

#### STANDARD BANK BUILDING - STRUCTURE

The superstructure is wholly carried on the reinforced concrete core, 46.5 ft. square in plan and 518 ft. high, founded on a 16 ft. thick reinforced concrete base raft. At each of three upper levels 8 prestressed concrete brackets reach out 41 ft. from the corners of the core and from each a prestressed hanger carries the edge beams of the 10 floors below. The core wall thickness varies from 24 in. at raft level to 7½ in. at the roof. The cantilevers are massive I sections with 4 ft. flanges, a 2 ft. web thickness and depth varying from 10 ft. to 18.2 ft.

The floors are lightweight reinforced concrete ribs 21 x 5 in. at 5 ft. 2 in. centres with a 3 in. topping. The reinforced concrete edge beam has an I section being 5 x 2 ft. overall.

#### EFFECT ON THE PLANNING OF THE SUSPENDED FRAME DESIGN

The consequences of the differences between the suspended and the conventional layouts on the planning of the building are now examined.

#### SEPARATION OF DESIGN INTERACTIONS OF DIFFERENT FLOOR LEVELS

In a tall building the uses of the various floors will be specialized and clearly defined.

The Standard Bank Centre has four distinct types of floor use, the office floors, the service floors, ground level and the basements. The basements require thin floor slabs and a flexible open vertical structure to take car parks and shops. It was decided to open up the ground floor as far as possible, to provide a public space among the narrow streets of central Johannesburg. The office floors with a 33 ft. clear width need an outer support to be economical. The plant floors required increased head room and open access for the installation of machines. One can produce expedients to satisfy all these needs with a normal structural layout but the difficulties in so doing are great. If one makes the adjustment to the suspended frame form all these requirements are immediately satisfied.

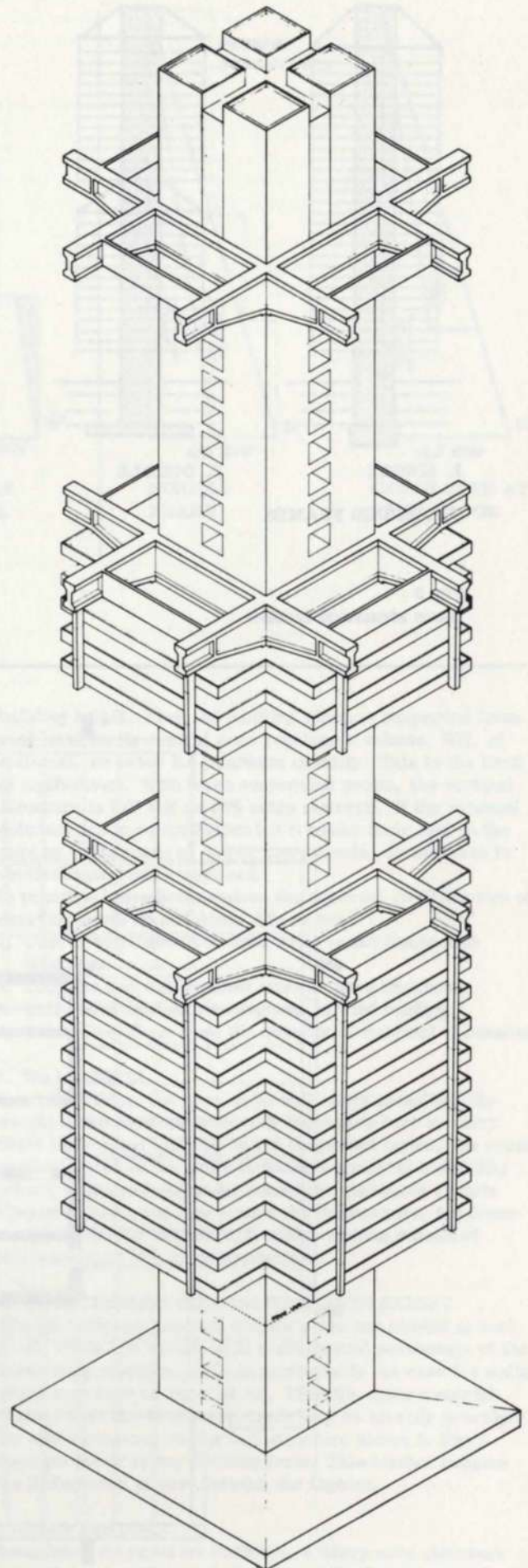

Fig. 2  
Standard Bank Centre, Johannesburg



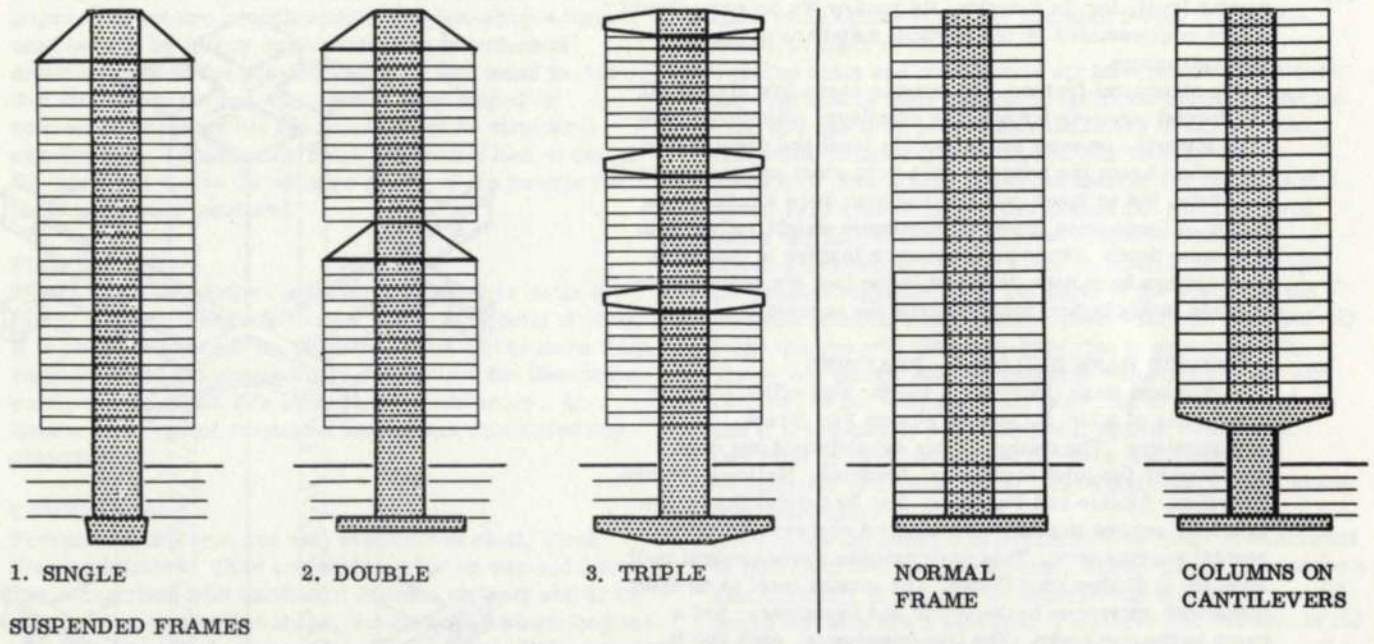

Fig. 3  
Basic structural frames

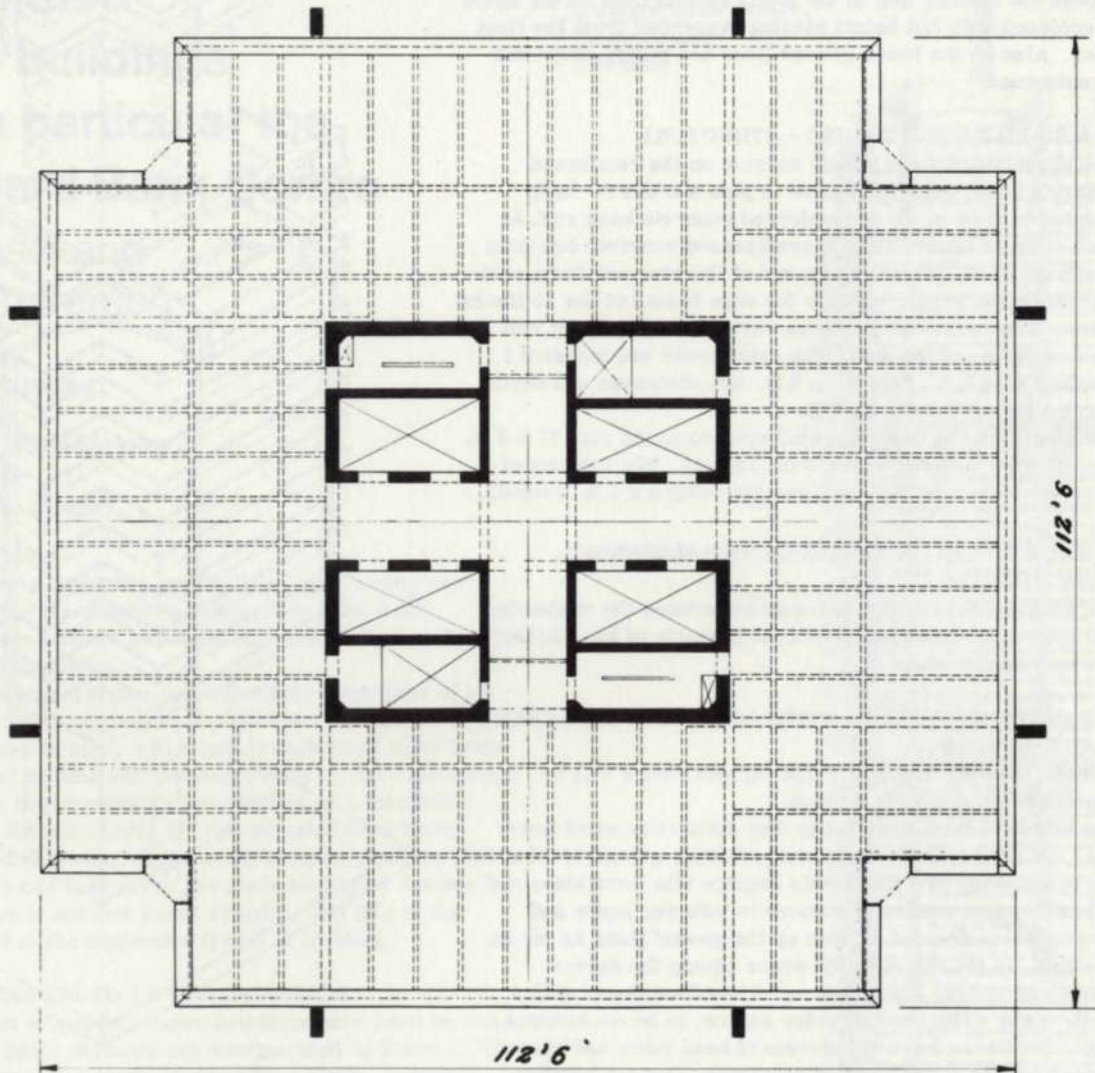

Fig. 4  
Typical floor plan



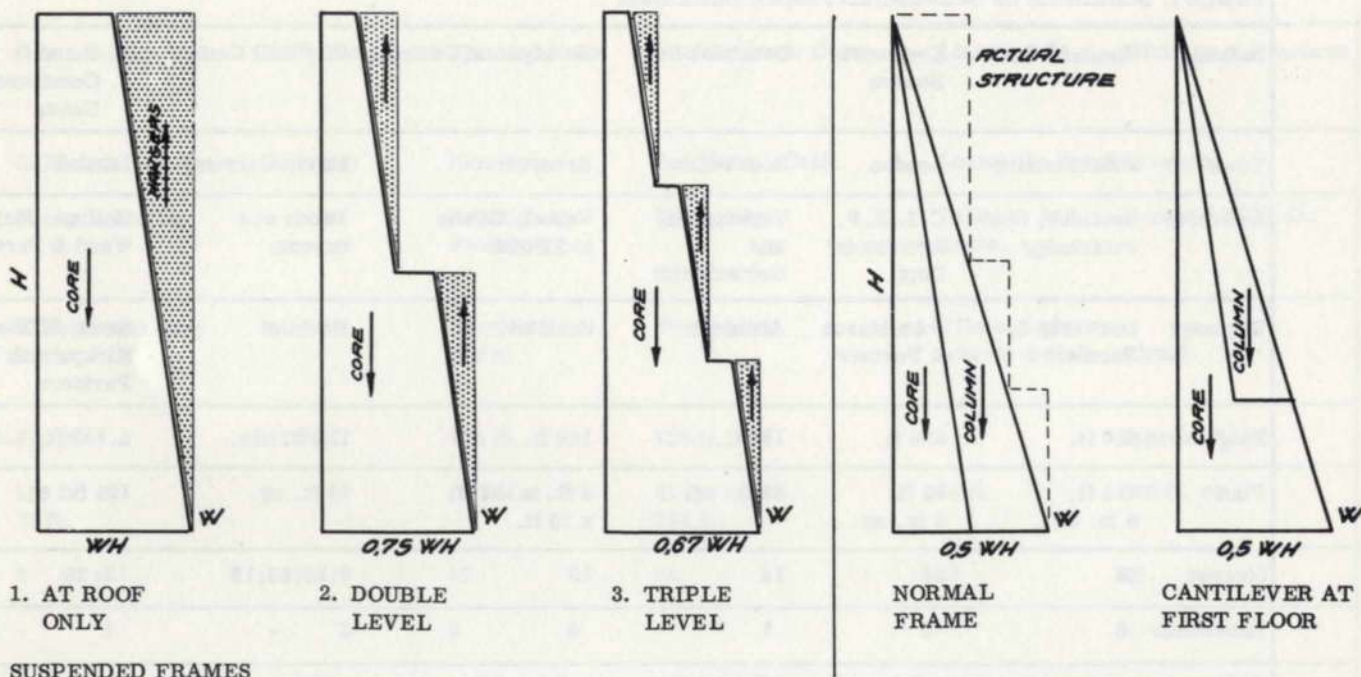

Fig. 5  
Vertical structure in tall buildings

#### EFFICIENCY OF UTILIZATION OF FLOOR SPACE

It has been claimed that the suspended form gives more efficiency of usable floor space, that is the ratio of the lettable area to the gross floor area. In fact, it does not in itself produce any significant improvement. The Standard Bank Centre has a maximum floor utilization of 75% in the office levels (Fig. 4), but this is produced by the square floor plan and the offset columns. The new Stock Exchange Building in London has a similar usable floor ratio but transmits its perimeter loads directly to the foundations. Nevertheless, the discipline of the suspended structure appears to sharpen the attitudes of the planner, or vice versa, and goes with compact layouts of services and access.

#### USE OF GROUND LEVEL AREAS

A most valuable area in a commercial building is the ground floor. It is visible, populated, accessible and is too good for use as a typical floor. Its two obvious uses are as an open public space or as shops. In Johannesburg, with its narrow rectangular street layout, the client felt that the provision of an open plaza was of such importance that the upper frame is suspended, the car parks are underground, the shops are beneath the plaza and even the branch bank is sunk into a glazed well to maximize the open deck effect. In the Euratom Centre in Brussels this has again been the reason for suspending the upper floors and a 6-acre street level area will result.

#### EFFECT OF SUSPENDING THE FRAME - ON THE STRUCTURE

We now examine in some detail the consequences of the suspended form on the structural frame itself. It is possible to be relatively precise about these factors.

#### ADDITIONAL VERTICAL STRUCTURE

The volume of vertical structure required for any given layout can be taken as a measure of its efficiency. The minimum volume is proportional to the sum of the products of the applied loads and the height through which they are carried, and this term,  $\Sigma WH$ , will be used here to define the volume of material.

Taking the typical perimeter column-central core layout as a basis of comparison, the sum of the loads  $\times$  heights is  $\frac{1}{2} WH$  as shown in Fig. 5, where  $W$  is the total weight and  $H$  is the

building height. Then the building which is suspended from roof level on its central core requires a volume,  $WH$ , of material, or twice the minimum quantity. This is the limit of inefficiency. With three suspension points, the vertical structure is  $\frac{2}{3} WH$  or 33% extra material. If the external columns are in compression but transfer their load to the core by cantilevers at one or more levels, no increase in vertical material is required.

In practice, four effects reduce the apparent inefficiencies of carrying loads up and down. These are:

1. Cost of reinforced concrete walls is not linear with thickness
2. Columns and walls cannot taper to zero thickness
3. Extra core load is advantageous in wind loading
4. Below first floor level the quantity of material is constant

#### 1. WALL COSTS

In a tall building the core walls will carry about half the weight of the superstructure. If these then have to carry twice their usual load due to the suspended layout, the cross-sectional area of the walls is doubled (ignoring instability effects in the walls) but the formwork quantities remain constant. Using average prices and thicknesses, the formwork represents half the wall costs, making a doubled thickness only 50% more expensive.

#### 2. REDUCTION OF COLUMN SIZES WITH HEIGHT

Though in theory minimal column sizes are needed at roof level, these are usually still a substantial percentage of the base cross-sections. This is particularly the case for walls, which may have no taper at all. Then the extra material required for the suspension loads may be already provided for other reasons. So the unit structure shown in Fig. 5 does not occur in any building form. This further relaxes the differences in cost between the layouts.

#### 3. WIND LOADING

Because of its superior stiffness, a heavy core structure attracts most of the wind shear in a tall slab-type building. The extra weight carried by the core will increase significantly the load factor against overturning.

#### 4. BASEMENTS

The weight from the superstructure must be carried through



TABLE I, SCHEDULE OF SUSPENDED FRAME BUILDINGS						
Building	Standard Bank	Kleinwort-Benson	Overbeek Huis	Berlaymont Centre	City Hall Centre	a. P and O b. Commercial Union
Town	Johannesburg	London	Rotterdam	Brussels	Marl, Germany	London
Architect	Hentrich, Petschnigg	C. L. R. P. Architects' Dept.	Verbruggen and Goldschmidt	Vestel, Gilson and Polak	Brock and Bakemo	Gollins, Melvin Ward & Partners
Engineer	Ove Arup & Partners	John Mason & Partner	Aronsohn	Schmidt	Hochtief	Scott, Wilson, Kirkpatrick & Partners
Height	460 ft.	290 ft.	184 ft.	140 ft.	113 ft. etc.	a. 191 ft, b. 387 ft.
Plan	112 ft. 6 in. sq.	95 ft. 6 in. sq.	89 ft. sq.	4 ft. x 151 ft. x 75 ft.	73 ft. sq.	124 ft. sq.
Storeys	34	24	14	13	8;10;13;13	13; 29
Basements	5	1	1	4	2	4
Core	reinforced concrete	reinforced concrete	reinforced concrete	reinforced concrete	reinforced concrete	reinforced concrete
Cantilever	prestressed concrete girder	reinforced concrete frame	prestressed concrete frame	high tensile preflex	reinforced concrete box girders	steel trusses with prestressed concrete core
Hangers	prestressed concrete	mild steel mullions	high tensile steel bars in precompressed steel tubes	mild steel mullions	prestressed concrete mullions	high tensile steel mullions
Floor Rib	lightweight reinforced concrete	Castella joists	rolled steel joists	rolled steel joists	reinforced concrete	Castella
Floor Slab	lightweight reinforced concrete	Holorib	lightweight reinforced concrete	reinforced concrete	reinforced concrete	lightweight reinforced concrete
Reason	Open ground floor	1st floor banking hall	balance of layouts, cost, speed	open ground level	mining subsidence	floor efficiency
State	building	building	complete April 1965	Part complete 1966	part complete 1966	building

the basements to the foundations. Whether a single core, or a core plus columns is used, the volume of this part of the vertical structure remains constant. On Standard Bank 30% of the total core concrete is used between first floor level and the foundations.

In summary, extra vertical structure is required but its cost is not as great as might appear.

#### ADDITIONAL HORIZONTAL STRUCTURE

##### SUPERSTRUCTURE

As the typical floor is unaware that its outer support leads upwards, its form should be identical to that for a normal building. Designers have tended to use minimum weight floors but similar criteria apply with conventional frames. The price of the head frame is clearly an extra. Its cost cannot be generalized. Shifting large perimeter loads horizontally through 30 to 40 ft. onto the core is expensive. The cost can be minimized by making the brackets very deep, which suggests a frame extending through one or more floors. The cantilever structure is usually integrated with the plant room arrangements.

Whether the cantilevers are concentrated into girders or are spread over the full width of the core is not important cost-wise. In Standard Bank where the cantilevers occur at intermediate levels the layout is restricted by the vertical services, stairs and lifts piercing up into the next set of floors. Then the web girder solution with a corresponding number of hangers is appropriate.

##### SUBSTRUCTURE

The loads which have been concentrated into the core require at foundation level to be spread out again. The size of the raft depends directly on the bearing capacity of the foundation material (with a minimum width when the line of thrust of the wind and vertical loads becomes too eccentric). If the raft bears onto sound rock, its cantilever span from the core area will be small and may involve little extra cost over the conventional foundation. If the tower loads are such that the raft area is equal to the typical floor area the cost of the raft is a similar amount to the cost of the upper cantilevers. The suspended frame tower is relatively most economic on a high bearing capacity foundation. Where sites are liable to subsidence two technical solutions



Building	Shermanoaks Bank	B.P. House	Finnland Haus	Pacific Trade Centre	Lincoln Life	Ministry of Pensions
Town	California	Antwerp	Hamburg	San Pedro, Calif.	Louisville, Keny	Brussels
Architect	Deasy & Bolling	-	Hentrich and Petschnigg	Termohlen	Taliesen Ass. Archs.	Bureau S.E.C.O.
Engineer	Wheeler and Gray	-	Leonhardt, Andra	Termohlen	Wilson, Andrews, Roberts & Noll	Lipski
Height	110 ft.	170 ft.	164 ft.	136 ft.	-	approx. 370 ft.
Plan	108 ft. x 72 ft.	-	66 ft. sq.	61 ft. x 164 ft.	96 ft.	100 ft. sq.
Storeys	8	13	13	11	15	35
Basements	-	-	2	-	-	-
Core	steel frame with concrete	reinforced concrete columns	reinforced concrete	reinforced concrete	reinforced concrete	reinforced concrete
Canti-lever	steel girders and trusses	prestressed concrete beams	prestressed concrete truss	steel trusses	steel trusses	-
Hangers	steel	steel cables	steel straps	steel straps	steel straps	steel straps
Floor Rib	steel joists	steel joists	reinforced concrete beams	steel joists	steel joists	reinforced concrete beams
Floor Slab	corrugated deck	-	reinforced concrete slab	corrugated deck	metal deck	reinforced concrete slabs
Reason	ground floor layout	-	overhang on building line	speed	extra floor area and flexibility	small site
State	building	completed	completed 1966	building	building	completed 1966

to the foundation problem are available. The superstructure can be arranged to be flexible enough to move with the soil without distress. This is suitable for low buildings. Alternatively the structure is made stiff enough and strong enough to move as a rigid body. For tall blocks the single core - suspended floor - solid raft form is particularly suitable. The group of four civic buildings at Marl is based on this idea (see Table 1).

#### STABILITY UNDER WIND LOADING

In tower block design the provision of a structure of adequate stability and a reasonable stress condition under wind loading is a controlling parameter. It is most satisfactory to carry the overturning moment by the prestress of the dead weight of the building. Maximum use of the self weight occurs when the vertical members carry their axial and shear loads in the same proportions. Since axial loads are a function of cross-sectional areas and wind moments are proportional to moments of inertia of members, this condition will be realised only when the vertical members are all equal in section and loading, e.g. when there is one vertical member.

To illustrate the increased core wall capacity to carry wind loading, assume that half the vertical load is normally carried by the perimeter columns and half by the core, at an equal stress, and that the wind force is carried mostly by the core. If all the vertical load is transferred to the core it will require twice the cross-sectional area and so twice the section modulus and be capable of carrying twice the wind moment. The overturning moment  $M$  is proportional to  $H^2$ .<sup>2</sup> approximately, and so the critical building height for design stress conditions in the core would be 37% greater with the suspended frame, if all the wind load were carried by the core in both cases. This extra available precompression will be lost if the core structure is articulated from the basement slabs, due to the increased effective cantilever length. The torsional stiffness of this structure is low but since suspended frames are not associated with whimsical floor plans, eccentric wind loading has not been important.

#### STRUCTURAL MOVEMENTS

Much more than in the normal layout the movements of the superstructure now control its design. When all the vertical



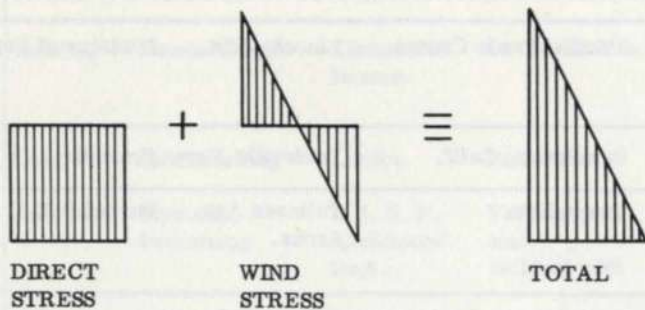

Columns direct to foundations

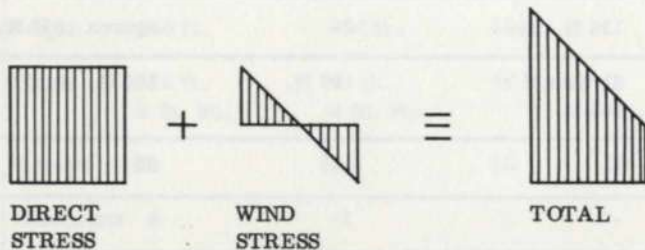

Suspended frame

(Notes for equal building sizes)

Fig. 6  
Wind stresses on core structure

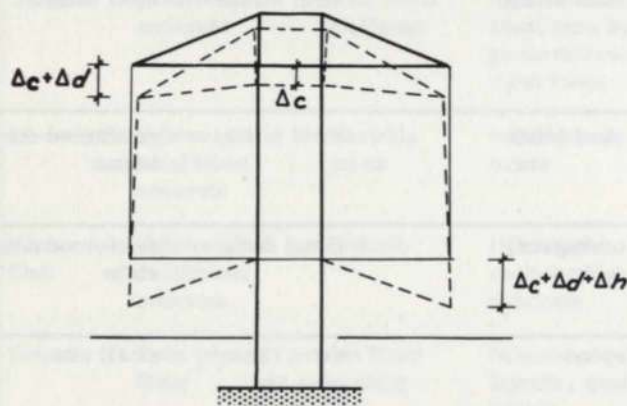

DUE TO VERTICAL LOADS

c = Core  
b = Bracket  
h = Hanger  
w = Wind

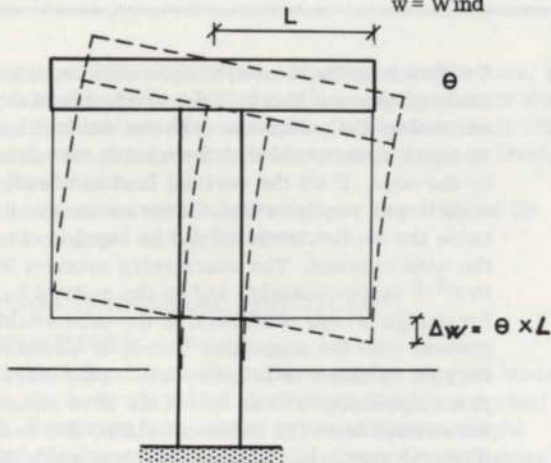

DUE TO WIND LOADING

Fig. 7  
Displacements of suspended frame

members are in compression their relative axial shortening is negligible. With the outer supports working in tension, member extensions are additive and include the movements of the cantilevers. Though there are no standards for permissible floor rotations, it is clear that neither the finishes nor the tenants should undergo distress. Means of reducing this undesirable effect are to use a low design stress, to limit the free length of hanger or to use a low strain material such as dense concrete. The critical vertical movement is that between the ground level and the first suspended floor. Here the elastic extensions, the creep of the core, temperature growth and wind rotation all add and special measures are required in any glazing which is used to enclose this space. (see Fig. 7)

To illustrate the order of these extensions, a table of values for various hanger lengths and materials is given (Table 2). Only vertical loading is considered, to which temperature, core sway, cantilever deflection and creep must be added. An idealized constant stress hanger has been assumed and the design live load is taken as 20% of the hanger load. The total displacement is not critical, as the floor self weight and probably also the cladding, finishes and partitions can be allowed for with varied initial cross falls in the floors. The partitions must be arranged to fit into the parallelogram created by the live load deflections - though the chance of 30 floors carrying 60% of this maximum live load simultaneously is small. The prestressed concrete section is heavier than the steel hanger and attracts larger local bending moments, whose stresses must be included in the hanger design. This reduces the attraction of a material which is superior to steel in its extensional character.

Table 2. HANGER EXTENSIONS IN INCHES

Hanger length	100 ft.		300 ft.	
	Total	Live Load	Total	Live Load
H.T. steel at 15T/sq.in.	-1.3	-0.3	-4.0	-0.8
Mild Steel at 10T/sq.in.	-0.9	-0.2	-2.7	-0.5
Mild Steel at 5T/sq.in.	-0.5	-0.1	-1.3	-0.3
Prestressed concrete	+0.1	-0.1	+0.2	-0.3

The effect of temperature changes is similar to that for any other building except that the lowest floor moves down where the upper floor would have risen. In tall blocks with full air-conditioning and an exposed external structure temperature stresses need detailed consideration. Prestressing the hangers or cantilevers induces relative movements and parasitic stresses.

To illustrate their order these are a summary of the vertical displacements of the outer edge of the first floor relative to its core support for the Standard Bank frame:

Due to self weight and prestressing	$\frac{1}{8}$ in. down
Due to live loads and finishes	$\frac{1}{8}$ in. down
Due to temperature rise	$\frac{1}{4}$ in. down
Due to creep of the concrete	$\frac{1}{4}$ in. down
Due to wind rotation	$\frac{1}{2}$ in. up or down
<b>Total</b>	<b><math>1\frac{1}{8}</math> in. down</b>

In the Standard Bank frame the joint between the cantilever and hanger is heavily stressed because of its temperature and prestress movements. The hanger follows the movements of the cantilever and attracts to itself excessive bending stresses. The upper two floors in each set have been articulated from the hanger by special suspension details and neoprene bearings to release these stresses. Under the design wind load the tower will move  $5\frac{1}{2}$  in. The natural period of vibration of the tower is  $5\frac{1}{2}$  seconds. The corresponding maximum acceleration at the roof is 0.02 g which is felt to be acceptable to the inhabitants.

#### 'CLEANNESS' OF STRUCTURE

From the engineer's technical viewpoint the suspended



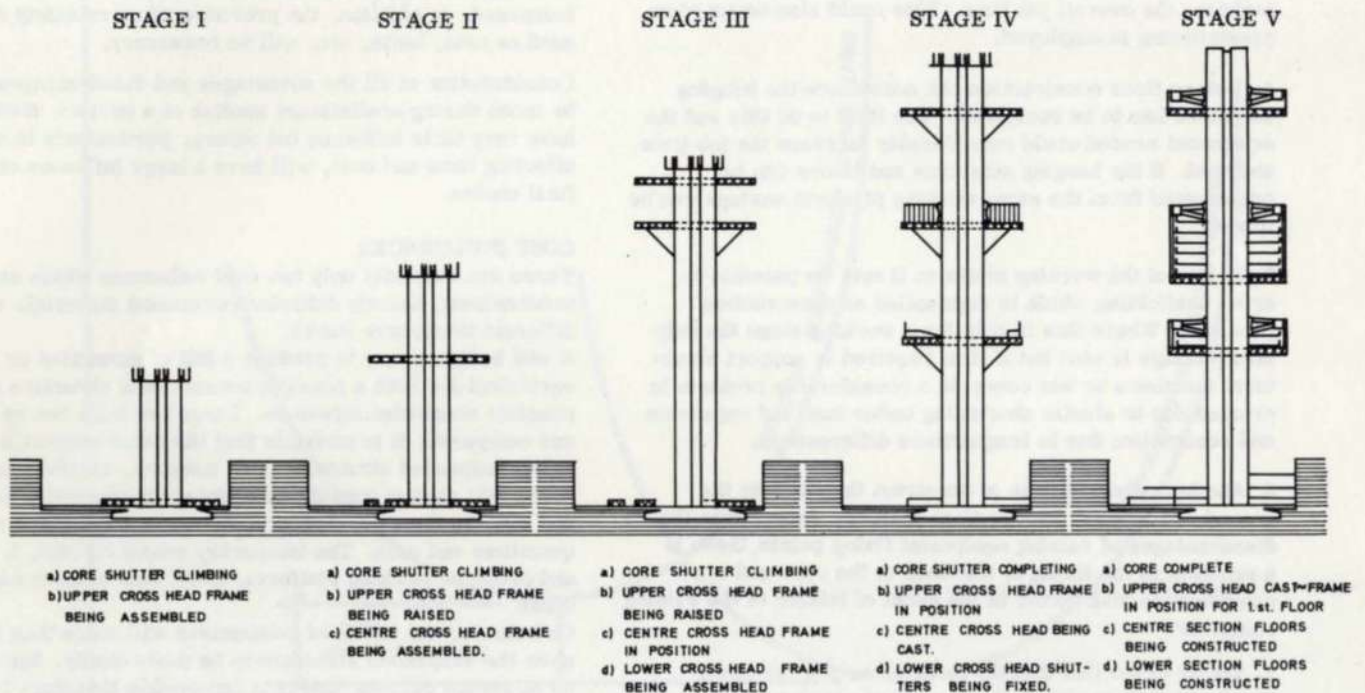

Fig. 8  
Method of construction Standard Bank Centre

building form is extremely satisfactory. There is little ambiguity in the means of transferring loads, vertical and horizontal, within a suspended frame. Over-design to include for different possible modes of structural action is eliminated. The extra work which the structure has to do imposes a stricter discipline on the planner's layouts, removing the eccentricities from the floor plans and limiting the occurrence of untypical floors. It seems in its present applications to have had no ill effect on the users' or the spectators' amenity. It would appear that the office block designer has normally too few controlling parameters for his solution and is obliged to make arbitrary limitations to complete the form.

#### CONSTRUCTIONAL CONSIDERATIONS

Regardless of the architectural, aesthetic and design considerations in selecting a suspended structure there are a number of constructional advantages and disadvantages which must also be considered.

#### ADVANTAGES

1. In a suspended structure it is necessary to construct the core first. It is, therefore, possible to begin work at a fairly early point in the programme on all services which are contained in the core. The installation of the main feeds of electricity and water will invariably aid the contractors and the installation of the lifts (which will need protection) will considerably speed up access for men and small materials.
2. In structures where there is more than one suspension level it will be possible to construct more than one floor at any one time. This could possibly speed up the overall job time. (Fig. 8)
3. Since floor construction proceeds downwards it will be possible to carry out glazing and external painting from the top downwards. This will eliminate possible damage to glass and paint due to falling objects, refuse, etc.
4. Downward working on the external faces of the building will enable cradles to be used, thus eliminating the necessity of scaffolding, resulting in a financial saving and the saving of time due to dismantling the scaffold on completion.

5. Since the highest levels will be tackled first any teething troubles in the placing of precast units, casting of in situ exposed concrete, fitting cladding units etc., will occur at a level where any slight discolouration, honeycombing, out of line or level, will be least noticeable and the troubles will be solved by the time levels at which faults would be noticeable are reached.

6. As soon as floor construction is complete, work on internal finishings can commence. These will not be delayed by the presence of props which may have to stay in place during the casting of three or four floors above.

7. Owing to the fact that any floor under construction (except the uppermost) has a completed floor above it, the contract programme will be a lot less affected by inclement weather. Rain will not wash off mould oil or flood formwork. Snow will not have to be cleared. Keeping concrete warm during curing in cold weather will be easier and temperatures of working areas can be raised giving an increased output.

8. Since completion works downwards damage due to through traffic of personnel, materials and rubbish will be considerably reduced.

9. Occupation of the penthouse flat will be possible earlier!

#### DISADVANTAGES

1. A working platform will be needed. The structure of the platform will vary considerably depending on the type of floor construction used and the method of suspension. Where the floor consists of in situ concrete the platform will have to be in effect a shutter and have to be sufficiently rigid and strong to take wet concrete. At the other end of the scale when the floor is made up of precast units or steel beams which connect directly to hangers, the platform will merely be a staging.

2. A working platform will require fixing points in the permanent structure both for securing it at a particular level and for holding the lowering or raising equipment. These fixing points may necessitate holes, rebates, etc. and extra reinforcement, all of which may be undesirable in the permanent structure.



3. In floor constructions where the working platform supports wet concrete the delay due to curing time could increase the overall job time. This could also occur when prestressing is employed.

4. Before floor construction can commence the hanging structure has to be completed. The time to do this and the equipment needed could considerably increase the job time and cost. If the hanging structure and floors can be constructed from the same working platform savings can be made.

5. In lieu of the working platform it may be possible to erect scaffolding which is dismantled as construction proceeds. Where this is only for a working stage the only disadvantage is cost but if it is required to support structural members or wet concrete a considerable problem is created due to elastic shortening under load and expansion and contraction due to temperature differentials.

6. Another alternative is to construct the floor on the ground and raise it into its final position. Apart from the disadvantages of raising equipment fixing points, there is a problem in the fixing of the floor to the core and a considerable risk factor in the event of failure of the raising equipment.

7. Owing to the fact that the floor above the one being constructed is in place, the placing of concrete direct by crane would be impossible and a more costly method involving barrow runs etc. would be necessary. For the same reason the hoisting of reinforcement, hollow pots, ducting, etc. would be more expensive.

8. If the floors are to be constructed in precast units the operation will be more difficult than in a conventional building for the same reason as above. This will also involve more cost. Precast floor units would have to be light enough to be placeable by hand.

9. As there is no structure below the floor being worked on, the danger of objects dropped from a floor is considerably increased. In addition, the provision of more safety devices such as nets, belts, etc. will be necessary.

Consideration of all the advantages and disadvantages should be made during preliminary studies of a project. Some will have very little influence but others, particularly those affecting time and cost, will have a large influence on the final choice.

#### COST INFLUENCES

There are basically only two cost influences which are predominant, namely different permanent materials and different temporary works.

It will be necessary to produce a bill of quantities or an equivalent for both a possible conventional structure and a possible suspended structure. These two bills can be priced and compared. It is probable that the basic support members in the suspended structure, i. e. hangers, cantilevers and core, will show a considerable excess in quantities and cost and that the floor construction will show a reduction in quantities and cost. The temporary works content, i. e. struts and props or working platform, could well balance each other.

On balance, the result of comparison will more than likely show the suspended structure to be more costly, but this is by no means certain, and it is impossible therefore to be categorical.

#### TIME INFLUENCES

Although the probable increase in quantities in a suspended structure will result in an increase in overall contract time this can in fact probably be overcome by an increase in the labour force or in output.

The only satisfactory way of finding the time influence is by creating a network analysis of the alternative construction sequences and by putting times for the various activities,

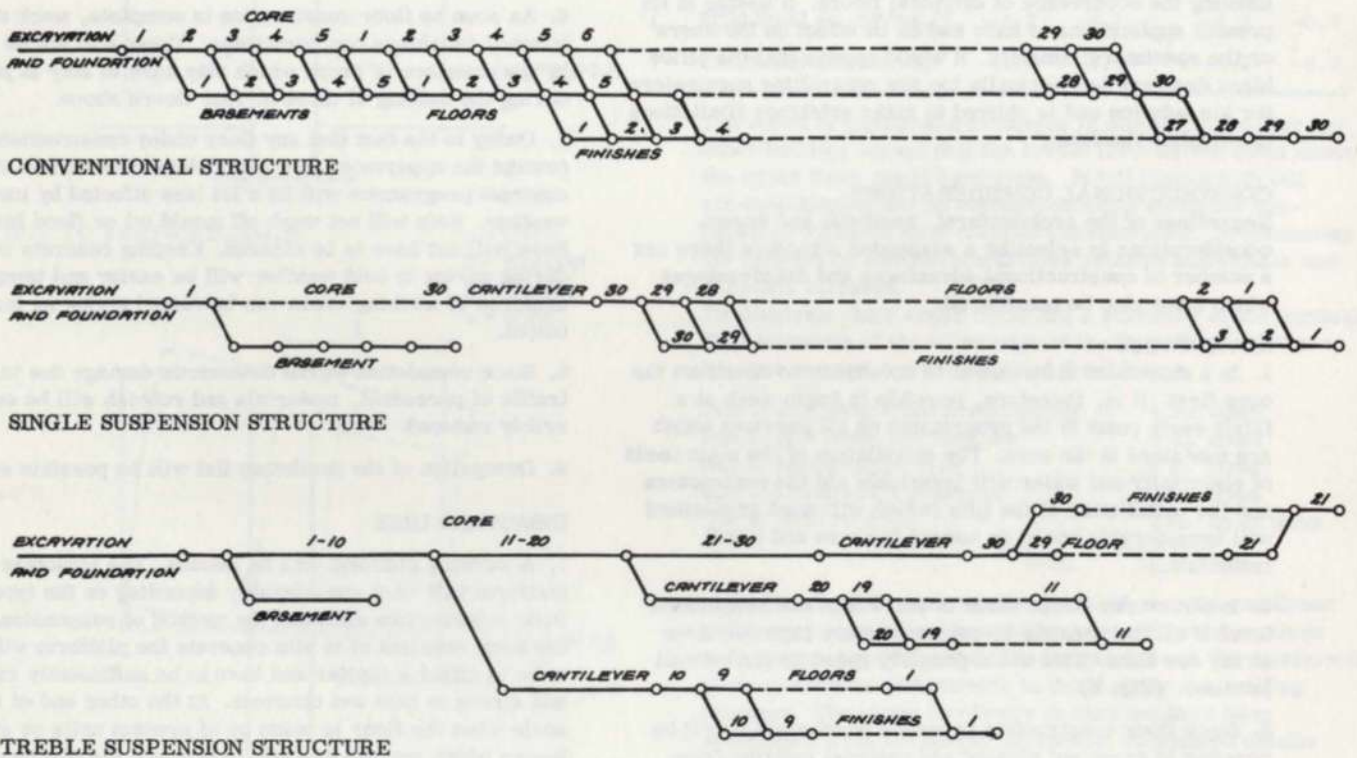

Fig. 9  
Networks of construction



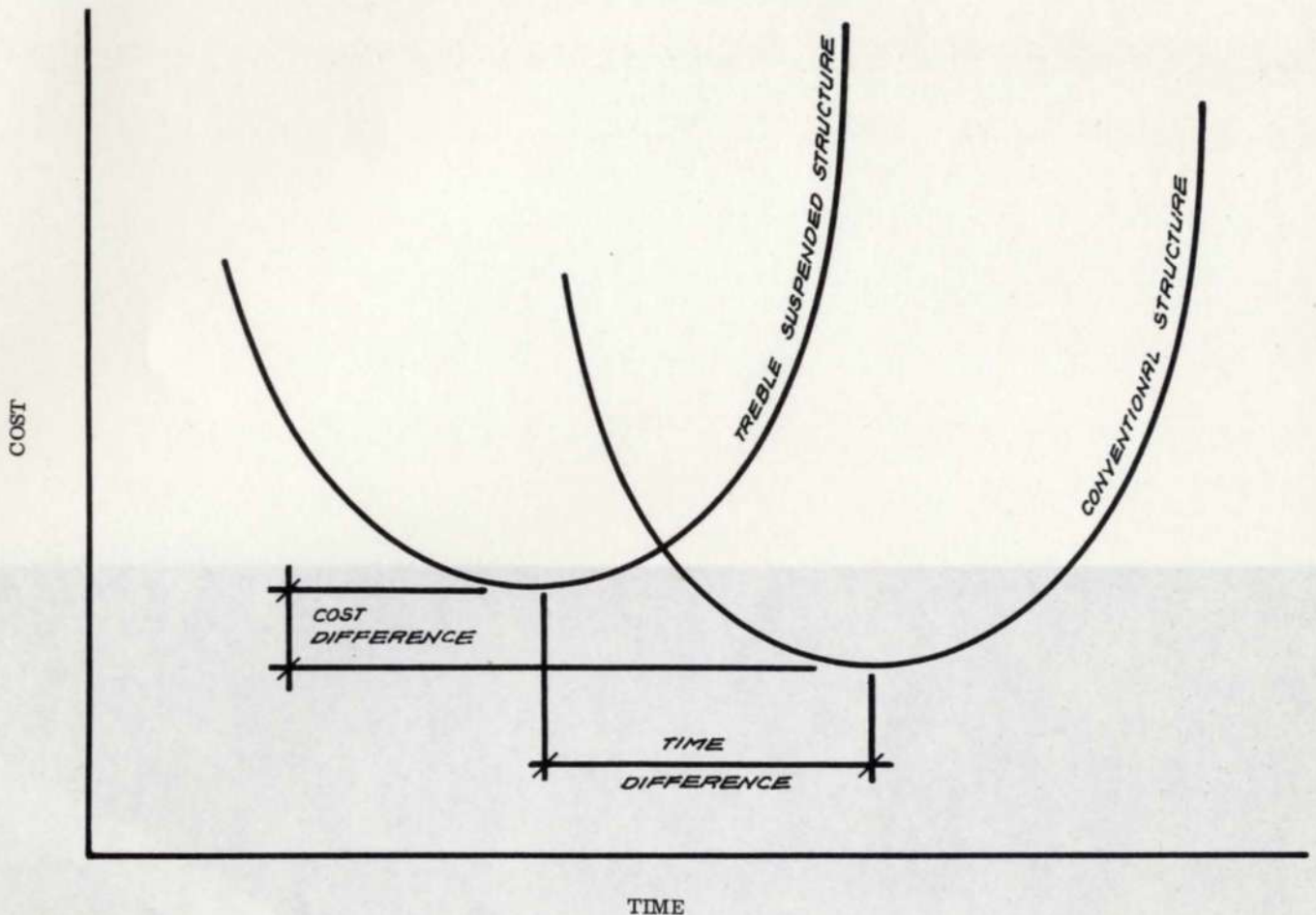

Fig. 10  
Cost/time curves

arriving at an overall critical path for each. The number of critical paths is infinite and will vary with the number of basements, number of floors, number of suspension points, extent of services, types of services and finishes, etc., etc.

Since in all buildings the services and finishes are completed after the structure shell one or more of these is invariably on the critical path. The type or extent of these will determine which one or more are critical and the earliest starting time possible will be required. In the suspended structure the core will definitely be on the critical path and in the conventional structure probably, although not in its entirety. In this respect it is claimed that sliding formwork is faster than climbing formwork but evidence to date does not necessarily bear this out. It may be that when sliding techniques are further developed and designers and architects play their part by reducing the amount of reinforcement and number of openings, recesses, corbels, etc. that sliding will be far quicker than climbing.

Fig. 9 shows the basic networks, starting from completion of foundation, of a five-basement, 30-floor building of conventional, single suspension and treble suspension construction.

Comparing the networks in Fig. 9 it will be seen that the floor services and finishes start at different points on each. On the conventional structure this point comes after completion of the basement, core to third floor level and floors 1, 2 and 3. This is necessary due to the probable retention of propping. On the single suspension the point comes after completion of the core, cantilever and 30th floor whilst on the treble suspension after completion of the core to the tenth floor lowest cantilever and tenth floor. Since the various time scales on these networks are infinitely variable it is, as with costs, impossible to be categorical with regard to time.

#### TIME AND COST CONSIDERATIONS

Time costs money and all considerations of time therefore must be converted to money in the final analysis. The construction of a given building has a minimum cost. This minimum cost has an optimum time represented by the maximum use of resources and overheads. Variations from this time, either shorter or longer, will cost more since the former will only be possible by the increase of resources to cover peak working periods with consequential excess costs in slack periods and the latter will result in the uneconomic spread of excess overheads.

This cost-time relationship can be shown graphically and two such curves are illustrated in Fig. 10. The curves are arbitrary and the preceding remarks regarding categorical conclusions must be borne in mind where considering them. In the figure the treble suspended structure is shown as having a higher minimum cost at a shorter optimum time compared with the conventional structure. The difference can be expressed as extra cost per week or month saved and equated to income from rent per week or month. The result of this comparison can be used in the overall assessment.

#### CONCLUSION

The final choice of structure will depend on all the foregoing influences. The result of the assessment will ultimately be governed by the terms of reference from the client and whether these require a prestige appearance, maximum letting area, early occupation, a cheap structure and other criteria or all the various combinations of these.



...the most important thing is to make sure that the  
...the overall quality. That is, the overall quality  
...is a must.

...the most important thing is to make sure that the  
...the overall quality. That is, the overall quality  
...is a must.

...the most important thing is to make sure that the  
...the overall quality. That is, the overall quality  
...is a must.

...the most important thing is to make sure that the  
...the overall quality. That is, the overall quality  
...is a must.

...the most important thing is to make sure that the  
...the overall quality. That is, the overall quality  
...is a must.

...the most important thing is to make sure that the  
...the overall quality. That is, the overall quality  
...is a must.

...the most important thing is to make sure that the  
...the overall quality. That is, the overall quality  
...is a must.

...the most important thing is to make sure that the  
...the overall quality. That is, the overall quality  
...is a must.

