

THE ARUP JOURNAL

JUNE 1982

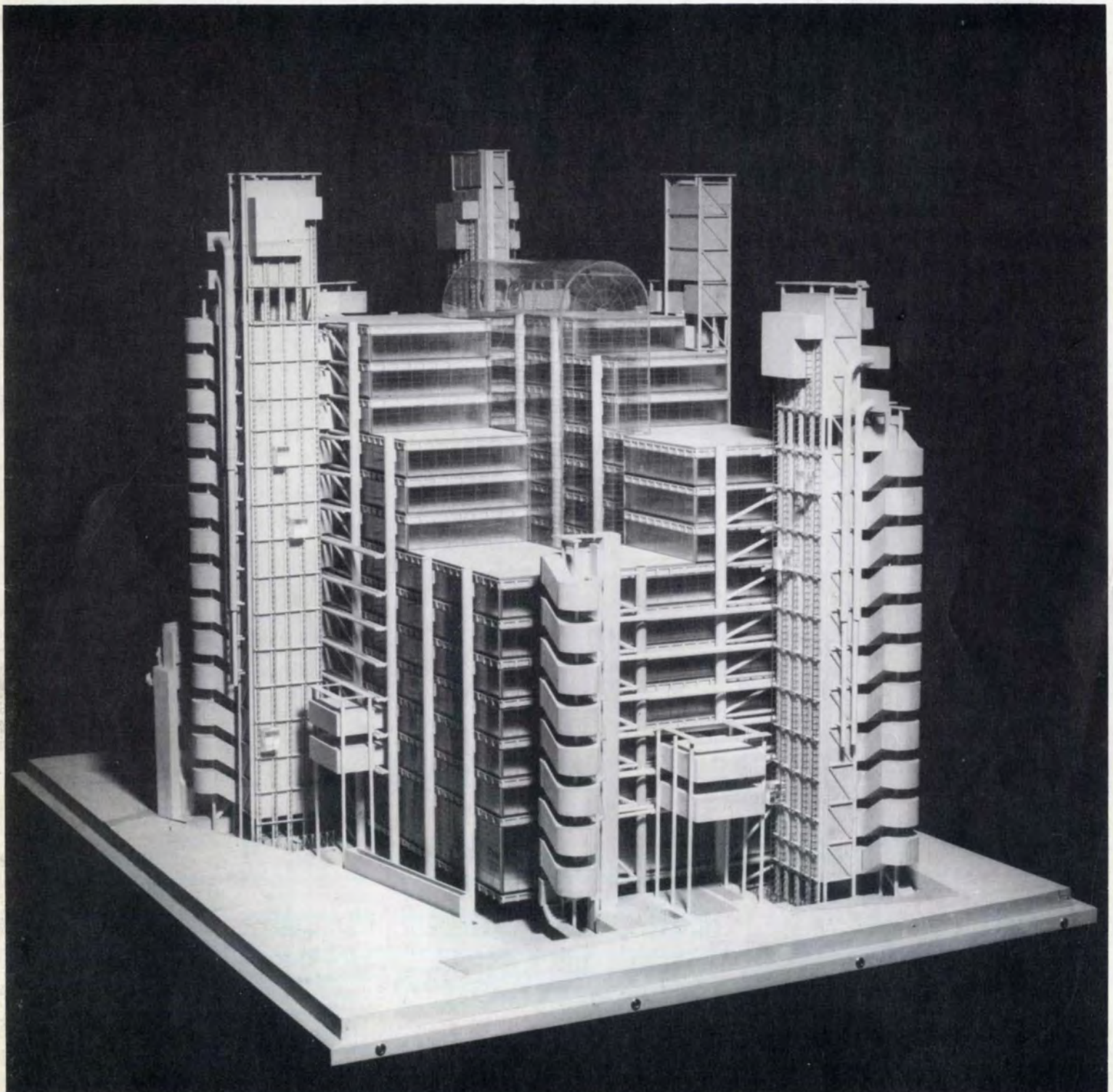

Lloyd's redevelopment by J. Thornton and M. Hall	2
NEC Hall 7 by R. Haryott and P. Budd	8
An alternative approach to ultimate limit state design by D. Croft	13
The shear stresses for reinforced concrete on CP110 by R. Whittle	18
Structural causes of non-structural defects by P. Beckmann	22

Front cover: Model of Lloyd's redevelopment (Photo: John Donat)

Back cover: NEC Hall 7 in Arena mode for a concert (Photo: copyright *Architects Journal*)

Lloyd's redevelopment

Architects:
Richard Rogers & Partners

John Thornton
Martin Hall

A brief history

The history of Lloyd's begins in 1688 when a London coffee house, owned by Edward Lloyd, with a clientele of merchants, became known as a centre of reliable information about shipping. Merchants with ships and cargoes to insure began to frequent Lloyd's coffee house where they engaged brokers to place marine insurance with wealthy men prepared to put their personal fortunes at risk. Since that time Lloyd's has developed into a unique international insurance market.

Insurance can only be placed at Lloyd's with Lloyd's underwriters who accept risks on behalf of syndicates comprising elected 'Underwriting Members of Lloyd's' and may only be placed by a Lloyd's brokerage company. A member of the public would not have the specialized knowledge to enable him to find the appropriate underwriter and negotiate advantageous terms. The underwriters work in 'boxes' situated in the Underwriting Room, known simply as 'The Room', which is a market where business is negotiated in a competitive atmosphere. The efficiency of Lloyd's depends on the existence of this single market place.

Redevelopment

Since its beginning Lloyd's has occupied a number of buildings and in 1977 it was decided that the existing accommodation would soon be inadequate. Realizing that it would not be possible to rehabilitate the existing 1928 and 1958 buildings, located on either side of Lime Street, the Committee of Lloyd's invited six leading architectural

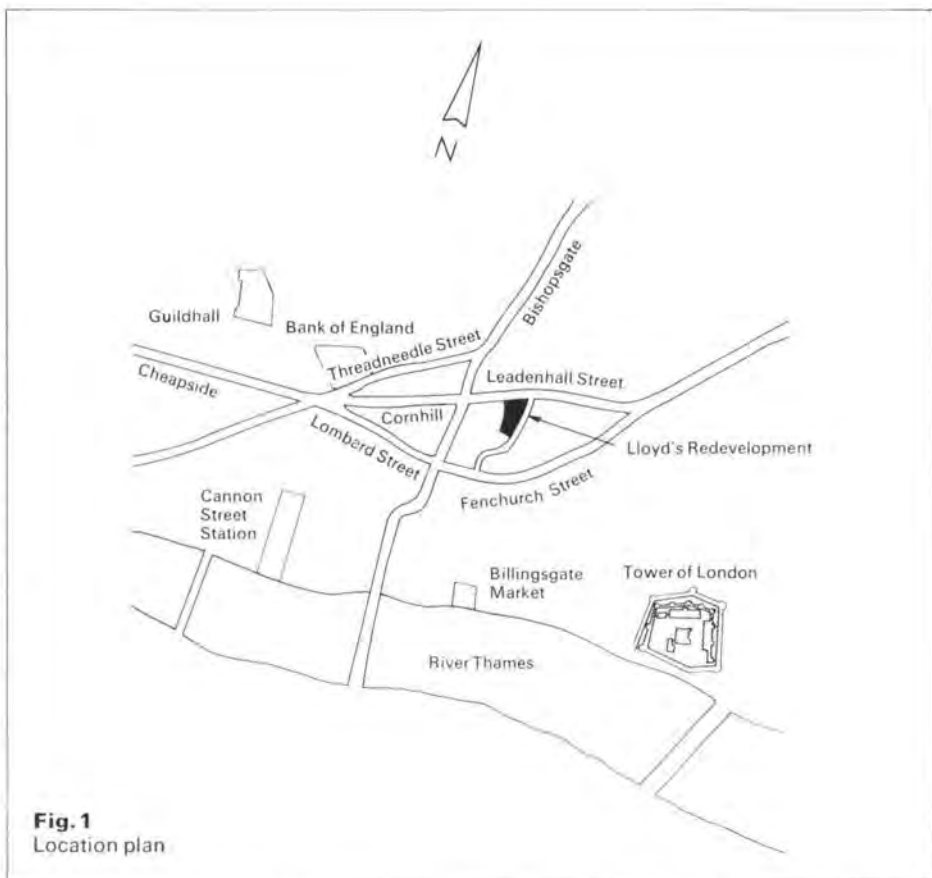

Fig. 1
Location plan

practices to enter a two-stage competition for the redevelopment.

Architects Richard Rogers and Partners, with Ove Arup and Partners as structural and services engineers, won this competition by defining what was essentially a design strategy rather than a building. The key points of the strategy proposed were:

- (1) That it allowed for maximum flexibility of use
- (2) That it gave continuity of trading and preserved the Lloyd's tradition

(3) That it did not rely exclusively on providing a new Room as quickly as possible but gave Lloyd's a means of maintaining expansion of business in the short term.

The redevelopment eventually proceeded by installing portable buildings on the roof of the 1958 building and converting the basement garage into underwriting space, beneath the existing Underwriting Room. At the same time many of the service activities were moved to nearby London House. This enabled the 1928 building to be emptied for demolition.

Concept

The building consists of a rectangular block, containing an atrium, surrounded by six satellite towers (Figs. 2 and 3). A two-storey basement occupies the entire site. As a broad principle the main building above ground level contains underwriting and office space. The satellites provide vertical circulation for both people and services and the basement contains plant-rooms and service activities.

The most important single aspect of the design is the need for flexibility. Lloyd's have already had to redevelop twice this century because of lack of space and the need for the building to be able to adapt to change underlies almost all major design decisions. By concentrating lifts, stairs, service risers and toilets in the satellites and supporting the main building floors on external columns, the floor space within the cladding is entirely unobstructed and restrictions on use are minimized. The design of the overall floor structure and the way in which the building is designed to a fixed grid means that internal rearrangement can be carried out with a minimum of disruption. Because of the atrium it is possible for additional underwriting area to be provided, within the single space of the Room, by using gallery levels for underwriting.

The components and systems of the building are almost entirely exposed and are designed so that their function is as legible as possible. The satellites, the construction of the floors, the way the floors are supported on brackets from external columns and the cross-bracing used to provide stability, all help make the operation of the building explicit.

General description:

Main building

The main building is a rectangular block, 68.4m x 46.8m. The lower ground floor is set slightly below street level and contains public areas and a restaurant, together with the reinstated Old Library. The level above this is the Room, which is double height, and above this are 12 gallery levels built as rings around the atrium. Initially underwriting will be confined to the Room and the first two galleries, but the building is designed so that underwriting can expand to Gallery 6. Galleries which are not used for underwriting will be used as offices or let except for Galleries 11 and 12 which contain the committee suite. This includes the committee room which has been adapted from the original Adam Great Room at Bowood House, Wiltshire.

In order that the single space Room can be preserved, the underwriting galleries open directly to the atrium; the other galleries will be glazed. Circulation between the upper basement and the underwriting galleries is by escalators that criss-cross the atrium which is roofed with a barrel vault of glass and steel.

The first six galleries form a complete ring around the atrium but above that the galleries are cut back to suit the rights of light of adjacent buildings.

Each floor consists of a number of horizontal zones (Fig. 4).

- (1) The beam grid
- (2) The high level services zone which contains lighting, extract air, fire detectors and sprinklers
- (3) A steel panel which sits on stub columns at the beam intersections and acts as permanent formwork, supports acoustic absorbing panels and provides a services support grid
- (4) A concrete slab which is a fire barrier and supports a computer floor
- (5) The low level services zone which contains supply air, heat pumps, electrical power and telecommunications

Fig. 2
Typical floor plan

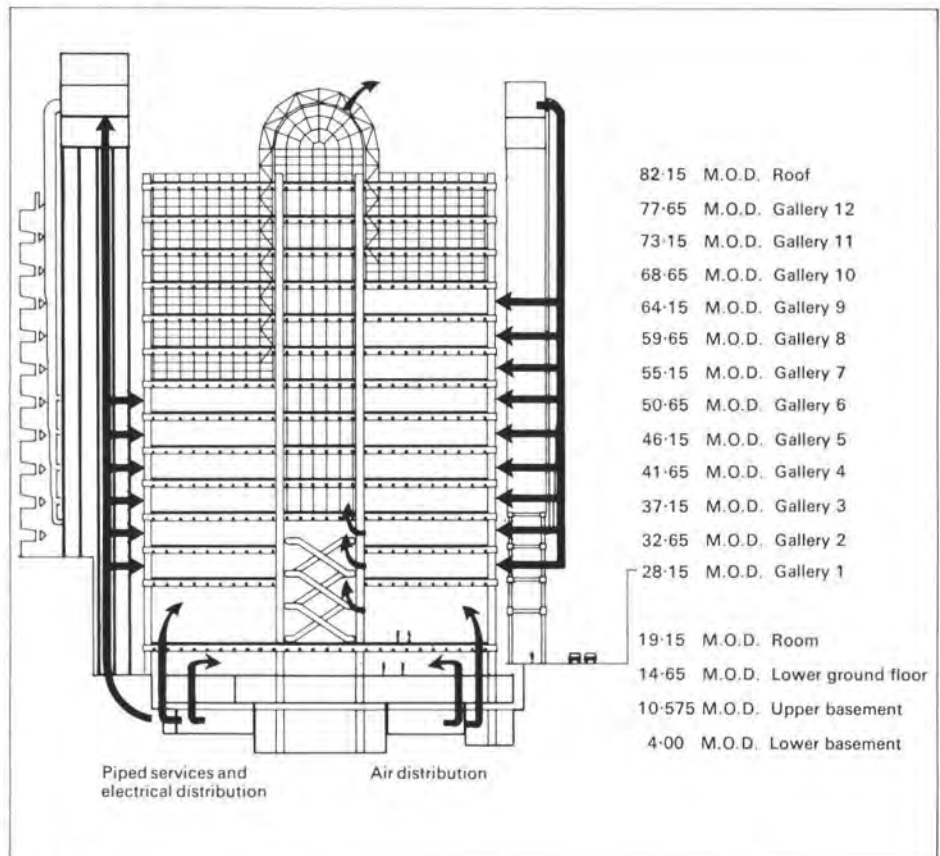
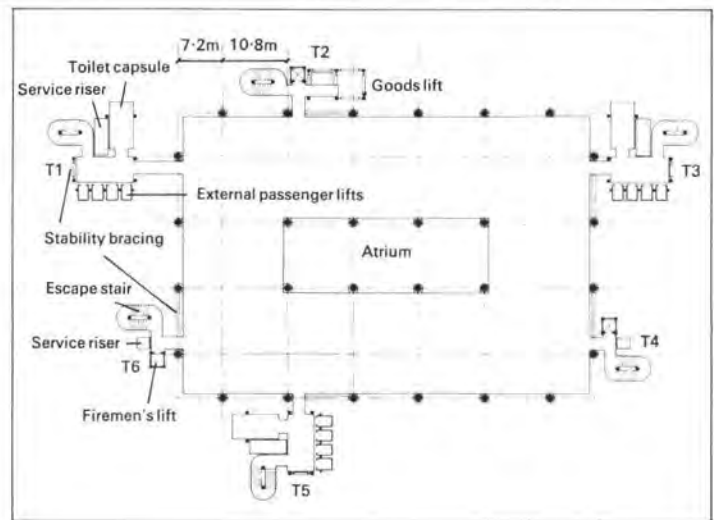

Fig. 3
Cross section

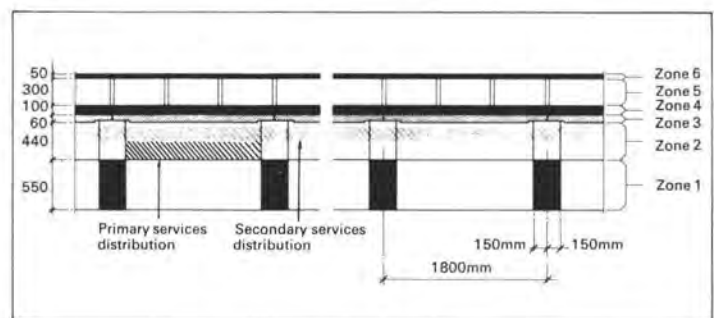

Fig. 4
Floor zones

- (6) The raised floor which is a modular panel system incorporating air inlet grilles and floor outlet boxes for communications and power.
 - (4) Because high level services are above the beams, partitions can be installed without having to trim around services. If necessary, closure of the high level services zone can be made with standard components.
- The cladding consists of triple glazed units arranged on a modular panel basis. Some of the panels are transparent while others have glass with a specially developed pattern which makes them translucent but gives the glass a sparkle. The cladding is used as part of the air circulation system and this is described in detail later.
- The zoning of the floor in this manner is fundamental to the concept of flexible space:
- (1) Supply services can be re-routed very easily.
 - (2) Both supply and extract services for a particular floor are contained within that floor so maintenance or alteration only affects the occupants of that floor.
 - (3) False ceilings, which are liable to damage, are eliminated.

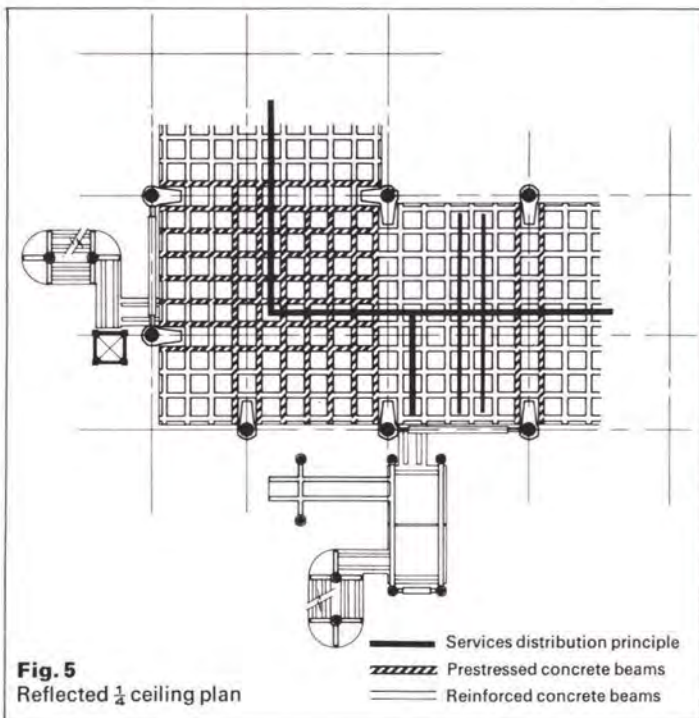

Fig. 5
Reflected $\frac{1}{4}$ ceiling plan

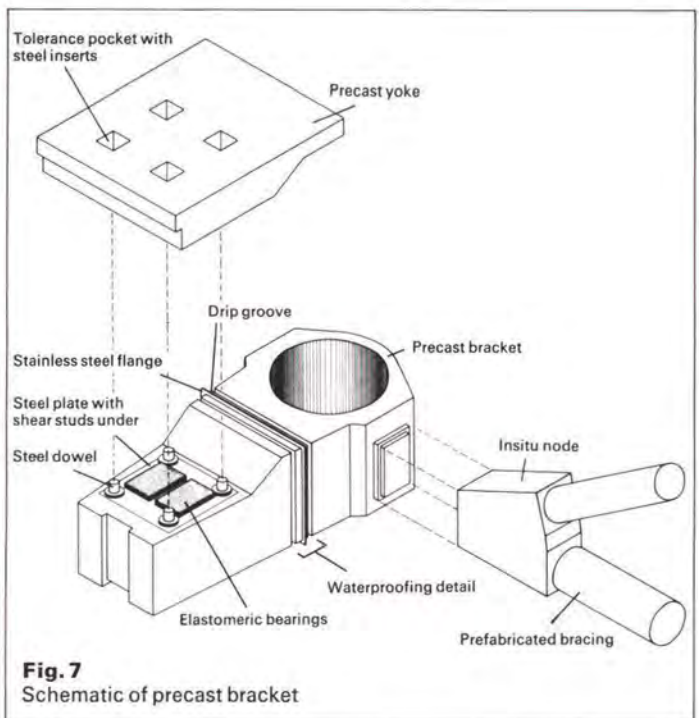

Fig. 7
Schematic of precast bracket

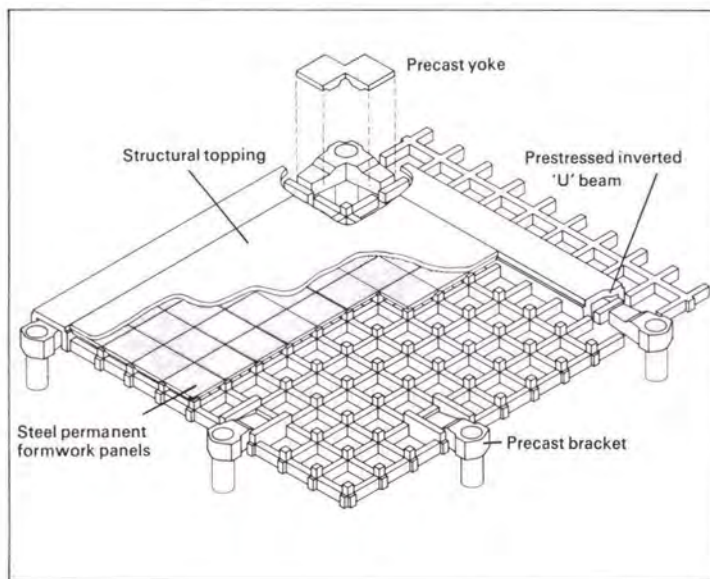

Fig. 6
Axonometric
of a corner

Satellite towers

There are two main types of satellite tower. Satellites 1, 3, 5 are circulation satellites; they are all essentially the same and consist of a lobby, four high speed external passenger lifts, a staircase, toilet capsules and a services riser. The staircase is constructed as a spiral around a pair of columns. The toilet capsules are complete enclosures which are independent of the main structural supporting framework and are lifted into position fully equipped. External services risers from the basement feed off at each level through the lobbies to serve the main building and also supply the air-handling plant rooms which are located on top of the satellites. Supply and return air ducts from the plant rooms run down the outside of the satellites and pass through the lobbies before running horizontally around the outside of the main building at each level.

Satellites 2, 4, 6 are fire-fighting satellites. Satellites 4 and 6 are identical and consist of a firemen's lift in an enclosed shaft, a staircase and a services riser. Satellite 2 contains a firemen's lift, staircase and services riser together with an external goods lift, which is supported by an open structural framework, and a roof air-handling plant room.

Each satellite has a crane mounted on top to give access for cleaning and each plant room is served by a lift.

Basement

The 'light' service areas for the lower part of the building such as kitchens and toilets are located in the upper basement whilst the 'heavy' services are contained in the lower basement. These 'heavy' services consist of the substations, standby generator room, boilers or chillers for the entire building and air-handling plant for the basements and lower ground floor. In addition the main stores are in the lower basement and because of traffic restrictions in the surrounding narrow streets vehicle access is provided by two hydraulic vehicle lifts of 10 and 24 tonne capacity. Also there are two hydraulic lifts for catering stores.

Structure: Main building

The final design of the floor was developed in direct response to particular architectural and constructional problems.

In addition to the reasons already given for the design of the floor, Richard Rogers wanted to avoid the appearance of the conventional waffle floor in which the recess is emphasized by the shape given by a plastic mould which is struck downwards. This was achieved by separating the beams from the slab and giving them vertical sides and sharp arrises; also there are no longitudinal joints on the soffits.

Separating the beams from the slabs meant a reduction in effective beam depth and the loss of the strength of the slab in T-beam action but had enormous advantages in ease of construction, freedom of services routing and visual clarity.

The layout of a typical gallery is shown in Figs. 5 and 6. The grid of 550 x 300 mm beams is supported on post-tensioned inverted U-beams which span between the columns. The distribution of forces on the grid is relatively uniform and the beams span both ways. The U-beams are prestressed using the CCL Slabstress system to reduce reinforcement congestion and control deflections. In the corner bays the 550 mm deep beam grid is prestressed to control deflections.

The U-beams are supported from the 1050mm diameter columns by precast concrete brackets (Fig. 6, 7).

We could not find, on the market, a bearing which would carry the necessary loads and yet be thin enough to fit into the space available. We therefore developed our own bearing which was actually half the price of comparable proprietary bearings. The vertical loads are carried by elastomeric bearings, and horizontal stability forces, both direct and rotational, are transmitted by four steel dowels between the bracket and yoke above. Shear forces from the dowels are transmitted into steel plates and then into the concrete by shear studs. Tolerance is achieved by installing the dowels through pockets in the yoke above and, after prestressing, these are grouted.

Precast concrete stub columns support specially designed steel permanent formwork panels from the beam grid. These panels were developed using three manufacturers to make and test prototypes, each with modifications to suit his own preference. They consist of troughed steel sheet spanning onto channel members which are lipped to receive services' support fixings. Four demountable acoustic absorber pans, consisting of perforated steel sheet backed with mineral wool, are fixed under each panel.

Overall stability of the building is provided by six vertical cantilever trusses formed by diagonal bracing between pairs of columns. It was necessary for the bracing members to be as slender as possible to give space for the satellite links to pass through and so they are made of specially fabricated thick walled steel tubes, encased in concrete for weather and fire protection.

Connections between the bracing and columns are made by friction grip bolting to plates cast in the bracket nodes.

Satellite towers

The satellites are constructed of precast concrete using, generally, bolted structural steel connections. Because of this the structure can be erected quickly with no need to wait for connections to gain strength. The connections are protected from fire and corrosion by in situ concrete or grout which can be applied at any time.

Overall stability is provided by either a truss formed with diagonal bracing between the columns at the front of the lift lobby or by the firemen's lift shaft. These structures act as propped cantilevers supported at roof level by horizontal trusses which cantilever from capping beams at the top of the main building bracing. At each level the lobby slabs span as horizontal beams between the truss or lift shaft and the main building. The connection to the main building consists of two elastomeric bearings which carry vertical load and a stainless steel pinned hinge to carry horizontal load. Secondary elements such as staircases and toilet structures gain their stability by containing slabs which act as horizontal cantilevers from the lobby.

Basement

The column loads vary from 80–2800 tonnes and, because of the large loads and wide column spacing, piled foundations are required.

The borehole site investigation revealed a very sandy layer at the top of the Woolwich and Reading Beds and significant groundwater seepages and associated instability would be expected in bored piles at this level. The piles are therefore formed entirely within the overlying London Clay. Because of the wide range of column loads, groups of 750 mm diameter straight shafted piles are used.

The new basement falls within the perimeter of the existing brick and mass concrete walls which are retained and supported from the floors by concrete buttresses. In most areas the lower basement slab is below the old basement level but in only some of these areas do the existing foundations require underpinning. Where this is extensive or if a cut-off

into the London Clay is needed to prevent the ingress of water from the overlying Flood Plain Gravel then a diaphragm wall is used. In other areas conventional retaining walls and underpinning are used.

Much of the basement is below the water table and the waterproofing takes the form of a drained cavity between the retaining walls and a blockwork facing wall. The cavity principle is continued under the ground-bearing slab by providing a drained, no-fines concrete layer.

The upper basement and lower ground floor slabs span one way on to twin beams on the main column grids (Fig. 8). Within the area defined by the perimeter of the superstructure the slab is constructed using precast T beams which are infilled with lightweight blocks and have a structural topping cast over. This system gives a flat soffit with a good finish while saving weight and formwork costs. In addition it provides zones of services penetration both during design and construction and for future alteration. Because of the irregular shape of the peripheral areas it was not reasonable to use this system throughout but by banding reinforcement on the same 900 mm grid, zones of penetration are defined.

The twin beam system not only decreased the span of the slabs but also made it possible for main risers to be placed on the column grid. Intermediate basement columns were introduced to reduce the beam spans and hence the floor depth.

Engineering services: Concepts

Plant and service distribution systems are designed for complete flexibility of building use, including the conversion of further gallery levels to underwriting.

Underwriting spaces have exceptionally high occupancy levels requiring large volumes of fresh air to satisfy their ventilation requirements. This air is exhausted from the building through the roof of the atrium, the residual heat being recovered and recycled to the heating system.

The main building has a low ratio of perimeter to floor area resulting in relatively low specific fabric heat loss in winter time. Glazing has a low solar gain factor which, together with the shading provided by the

external structure, satellites and external air distribution ducts, results in relatively low heat gain from solar radiation.

The occupied spaces of 4 m height together with the low level air inlet and high level exhaust systems minimize the effective space cooling loads a large proportion of the lighting and occupational heat gains being exhausted before affecting the space conditions. Electrical consumption by artificial lighting is minimized by the use of twin lamp luminaires providing background and task illumination as required. The background illumination is provided by one lamp which is centrally controlled. The second lamp which provides working illumination is locally switched by the individual. Perimeter luminaires are automatically monitored to prevent use at times when natural light, infiltrating the building, provides adequate illumination.

A degree of thermal storage has been incorporated into the design, passively by the underfloor air distribution system in the superstructure and actively by the use of the fire sprinkler storage tanks as heat storage. The tanks are arranged to accept hot water, rejected by the central water chilling plant, for recycling in the building's central heating system at times of heat deficit.

Because the service distribution systems are exposed their planning and detail design had to satisfy architectural as well as engineering requirements.

Main building

The raised floor void provides the principal means of service distribution. Electrical power and communications systems are arranged in a modular grid to provide potential service at any part. The raised floor acts as a supply air plenum for the office and underwriting air-conditioning. Individual offices may plug their room air distribution units into the void and draw conditioned air into the occupied space, the air being exhausted around the luminaire at high level. To enhance comfort at the perimeter, the exhaust air is drawn back from high level through one of the triple glazing cavities before being returned to the air-conditioning plant. This has the effect of limiting the annual temperature range of the glazing and hence the radiant temperature experienced by the adjacent occupants (Fig. 9).

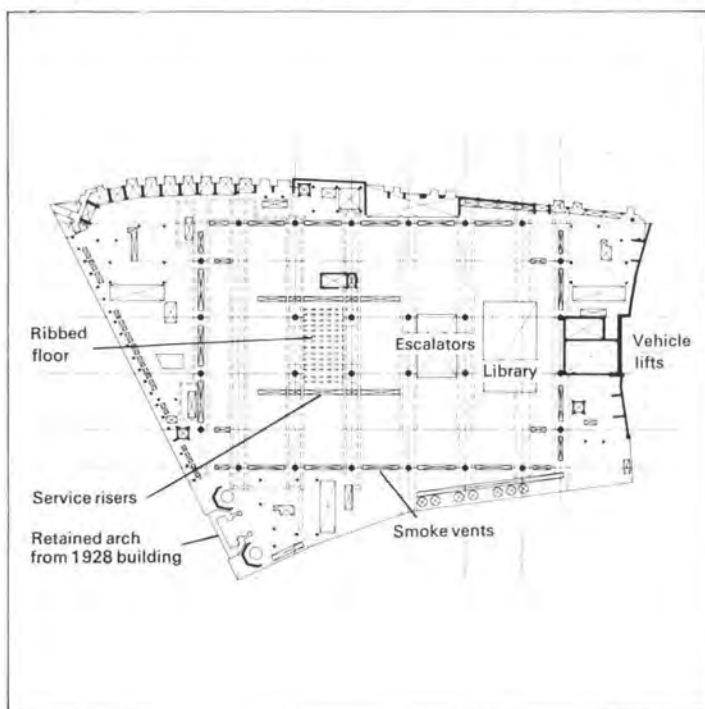

Fig. 8 Lower ground floor

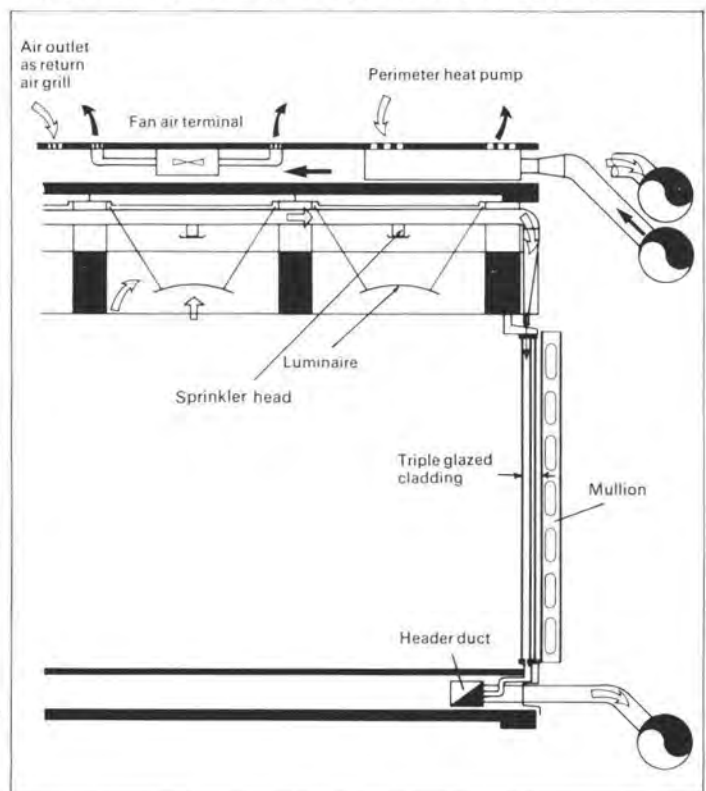

Fig. 9 Floor air distribution

Areas of underwriting and offices with abnormally high heating or internal cooling loads are provided with supplementary heating and cooling units. Together with their service pipes and drains these are located in the raised floor void.

Compliance with the requirements of a Section 20 Certification requires the fire sprinkling of the entire building and so each coffer has an outlet which is incorporated in the luminaire. In addition a fire detection and alarm system is provided for early warning. The following ancillary electrical systems are also provided: closed circuit TV and security system, public address system, staff location, data storage with visual display units, a 4000 line electronic telephone exchange and a satellite communication aerial. Lightning protection is given by horizontal roof conductors connected to down rods cast in the columns.

Satellite towers

Distribution of primary electrical and piped services to the main building is made from the satellites. Three combined electrical and communication risers serve the electrical/communication cupboards located in the passenger lift lobby at each floor level. The service risers, like the air distribution ducts on the building's façade, are entirely exposed to the weather. This necessitates high material specifications and a quality of workmanship best obtained with off-site fabrication methods. Maintenance access to the service risers is made at each gallery level from the lift lobbies.

The main passenger lift service is provided externally by 12 3m/s lifts in three groups of four lifts at satellites 1, 3 and 5. Design of the installation will be unique in the UK as such exposed installations are generally at present only in operation in the USA.

Basement

The design has, by passive means, minimized energy consumption whilst maintaining current standards of environmental comfort. This has been supplemented by the recovery of waste heat wherever economically possible. The central chilled water plant has the capability of rejecting energy into the central heating system at times of deficiency or discharging to waste through cooling towers at times of energy surplus.

The building's boiler plant and standby electrical generation plant are located at the north end of the lower basement where their respective flues are grouped. The flues pass through the upper basement to outside the building and then are carried on a supporting steel structure to the highest point of the building.

Primary fuel for the boilers is natural gas, being purchased under the same terms as the client's current contract with the gas undertaking. The boilers can also operate on the same diesel fuel oil that the standby generators use, thus optimizing fuel storage facilities.

The incoming electrical supply is at 11kV and is distributed radially to four packaged substations in the lower basement. Three substations serve the risers in Satellites 1, 3 and 5 together with the adjacent basement while the fourth serves the mechanical plant. Emergency lighting battery bank/inverter sets are located adjacent to the risers. Halon fire extinguishing systems are provided in electrical rooms instead of sprinklers.

Atrium

Few atria in the world are as large and have floors which are used for office space. A serious problem in the environmental design of a tall atrium is the effect of vertical air currents caused by air temperature differentials at the top and bottom. The differential temperatures generate a stack effect in the centre of the atrium and in winter the air adjacent to the glazing will fall thus generating turbulent air movement.

The air movements in the atrium will be extremely complex and are difficult to predict. Work on this is still in progress but it is intended that the conditioned air supplied to the underwriting levels should infiltrate the atrium and be exhausted at the top. The result of this will be to minimize unwanted downward air movements at the perimeter of the atrium by generating horizontal air currents and reinforcing the upward movements at the centre.

Building automation system

Efficient energy usage is achieved by intermittent use and close control of building systems. The building automation system will monitor and control mechanical plant ranging from local heat pumps to major plant and systems. The system will also be used to monitor all electrical systems and provide lighting control.

Mock-ups

A considerable amount of work has been carried out developing particular elements or processes and the culmination of this is the construction of a full storey height mock-up four grids x three grids in area.

The most important development work has been that concerned with the formwork design. To achieve the required quality of concrete finish while maintaining the necessary rate of progress, it is essential that the formwork system is properly designed.

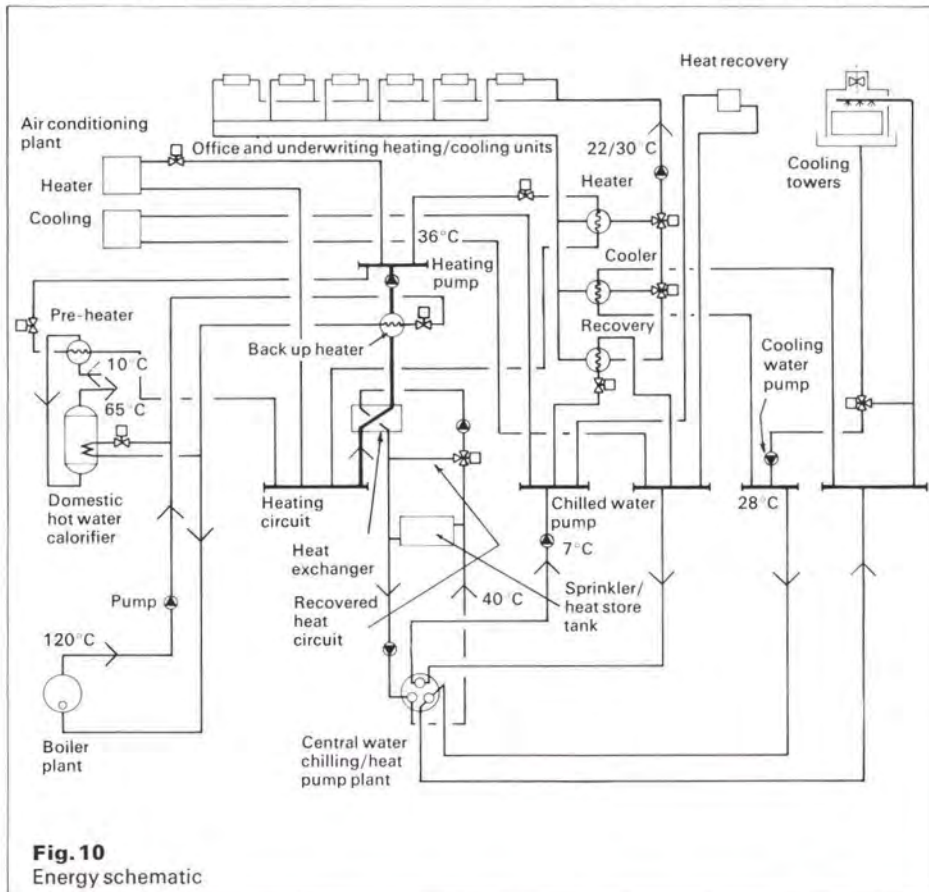

Fig. 10
Energy schematic



Fig. 11
Progress on site, March 1982
(Photo: Indusfoto)



12▲ 13▼



Fig. 12
Model
of Lloyd's
redevelopment
(Photo:
John Donat)

Fig. 13
Model
(Photo:
Richard Davies)

Fig. 14
Progress on site:
April 1982
(Photo: Indusfoto)

Because of the unusual structure of the floor the risk could not be taken of developing the system from scratch during a contractor's mobilization period. Three different formwork systems were developed and a number of trial sections of floor were cast. Three systems were offered to tenderers with the option that they could propose an alternative, in which case they were required to cast a sample during the tender period. The experience gained from the trials has been invaluable.

Another interesting test programme was load testing air handling ducts which are required to act structurally in the sense that they span much further than normal while carrying the extra loads of insulation, cladding, snow and wind.

Construction

Work on the 1958 building started in January 1979 and was completed in September 1980. Demolition of the 1928 building started in September 1979 and was completed in February 1981. Bovis were appointed as management contractors in June 1980 and construction started in February 1981.

Construction of the basement is in progress and a sub-contract for the superstructure was let in February 1982.

The construction of the basement has presented many problems, mainly associated with the temporary works. The existing foundations covered much of the site and have largely had to be removed, either because they were above the new basement level or because they obstructed piling. However, the steel shoring for the existing walls is supported from these bases and so foundation construction has involved considerable re-routing of forces; the planning of this has been extremely complex. The overall work sequence adopted involves completing the upper basement and lower ground floor slabs, destressing the steel props to transfer load to these slabs and then finally completing the lower basement slab. By this means the lower ground floor can be handed over as soon as possible for superstructure construction. The first area was released in May.

The client and design team

The client for the redevelopment is the Corporation of Lloyd's. The professional design team consists of:

- Architects:*
Richard Rogers & Partners
- Quantity surveyors:*
MDA, Monk Dunstone Mahon and Scears
- Management contractor:*
Bovis Construction Ltd.



NEC Hall 7

Architects:
Edward D. Mills and Partners

Richard Haryott
Peter Budd

The first six halls at the NEC were opened in the autumn of 1975, giving covered exhibition space of around 100,000m².

The original halls were planned on a 30m square column grid and were constructed economically and rapidly using a Nodus spaceframe supported on tubular steel box section trusses and columns. Headrooms varied from 12m to 17m and in part of Hall 5 there was a 60m square column-free area with a headroom of some 23m.

The original brief did not even call for air-conditioning or indeed any cooling except by outside air ventilation, and the heating requirements were fairly utilitarian with a requirement to achieve only 16°C in the worst weather. The cost per m² was kept quite low, bearing in mind the facilities provided in terms of electrical power, water, gas, drainage and so on to almost every part of the huge floor area. The original designs were made against a background of no operational experience by the NEC of any previous centre, and indeed no precedent existed in the UK with comparable facilities. In the first five years operation, the NEC have undoubtedly created a whole new successful industry and are now a considerable generator of employment in the area. They also discovered a demand for multi-purpose space for leisure activities, and were already staging pop concerts, sporting events and other arena-based shows in

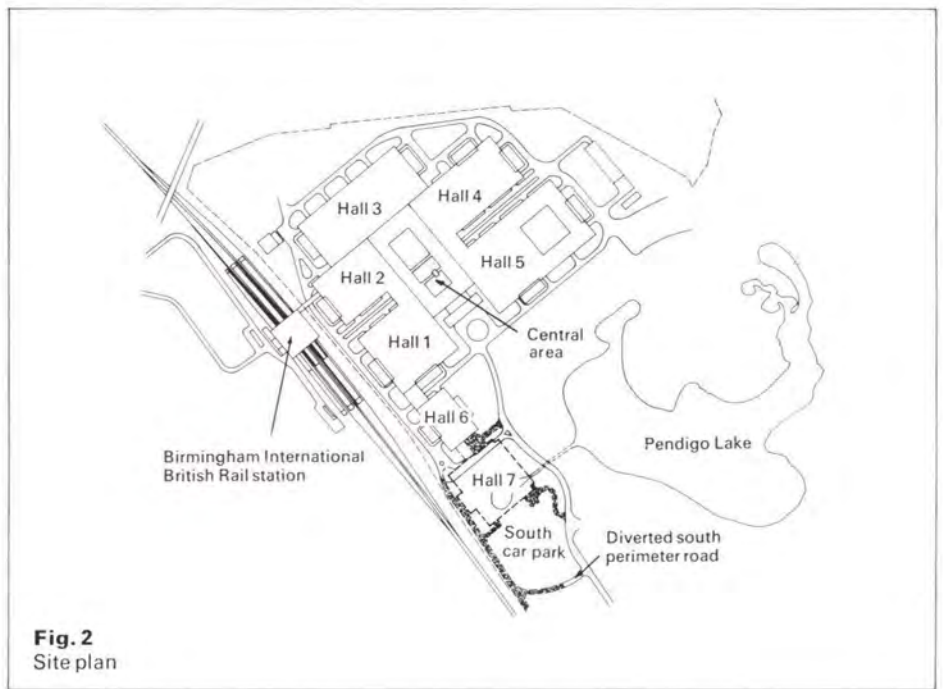

Fig. 2
Site plan

Hall 5, and had purchased a large amount of demountable seating for such activities. They also needed more exhibition space to be able to attract The Motor Show on a long-term basis, and for some of the large international shows, they needed a good deal more space. To progress they had to grow.

Early in 1979, the NEC looked set to conclude negotiations for The Motor Show to be held in October 1980, and approached the original design team of Edward D. Mills, Arup and Francis C. Graves to explore the possibility of adding 10,000m² new space in time for

The Motor Show. The design team was finally instructed to proceed in April 1979 and a completion date of August 1980 was agreed, leaving only 16 months to design and construct the new Hall.

The NEC at that time had already purchased a system of demountable seats which ideally the new hall should be designed to use, and as a result of their operating experience in the original halls, they required a change to environmental systems to give a much improved heating and cooling capacity to cope with large audiences, and to simplify maintenance. The new hall had to provide

Fig. 1
Hall 7 from across the lake (Photo: Harry Sowden)



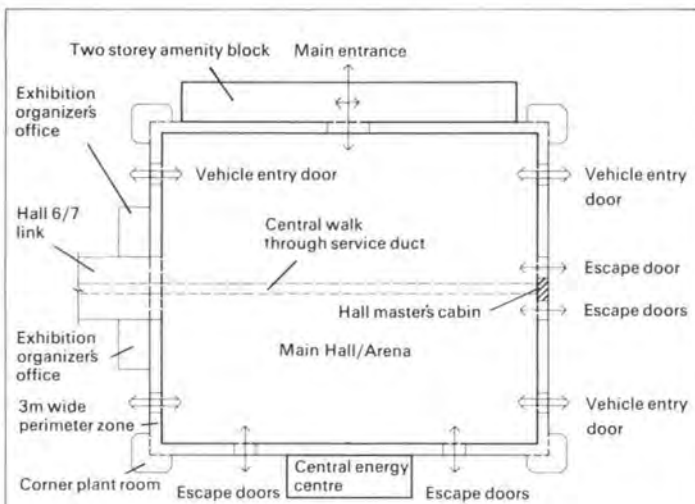

Fig. 3
Plan
showing
hall zones

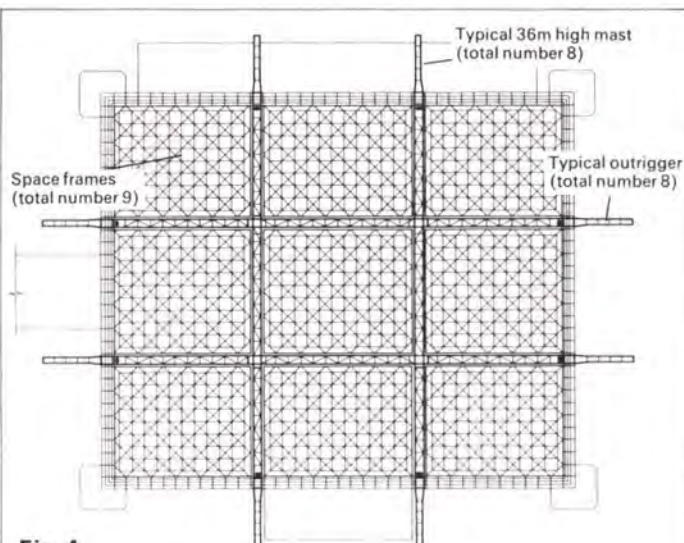

Fig. 4
Roof plan showing structural steel arrangement.
Nine space frames are supported on 3m deep
girders around the building perimeter.

exactly the same service facilities via underground subways and trenches as had proved to be successful in the original development. Restaurants, offices and other operational facilities were required to enable arena shows seating up to 12,000 people to be held, and of course the various arena layouts possible meant that the new building had to have a large column-free area of some 108m x 90m. A tight budget was set based upon the original m² costs with a factor to allow for inflation and a factor to take care of the increased span.

The client had also some clear preferences to change the utilitarian method of heating and cooling originally specified. He wanted a central plant (proposed but rejected on cost grounds for the original scheme) and wanted if possible to eliminate the roof-mounted air handling stations adopted for the first halls, as these were proving difficult to maintain although performing quite well.

Design approach

It was quite clear from the beginning that a conventional design, tender, and construction package would not achieve the programme. It was essential to start on site at the earliest possible moment, and probably more important, to have a contractor as part of the design team so that programming and design options would only be evaluated by people fully committed to the end result.

R. M. Douglas, who built the original complex were appointed contractors. In a way, it was done virtually as an extension of their original contract, which had not in fact been completely finalized. They undertook the contract for the rates on which they had won the original contract indexed by NEDO or some other formula, and started work on site within days of the design start, clearing the site and preparing the new infrastructure. The involvement of the contractor at this early stage was crucial to the time-scale, and right from the start they were deeply committed to programming the whole activity.

Clearly, as engineers we already knew a great deal about the site conditions. However, because site work had to start before the design was anywhere near settled, it was necessary to adopt an approach for the site roads and drains which did not restrict the choice of the exact position of the buildings, which was of course known in approximate shape only. It proved possible to fix certain aspects of the design without compromising the final design choices for the superstructure. At a quite early stage it was decided to separate completely the restaurant and

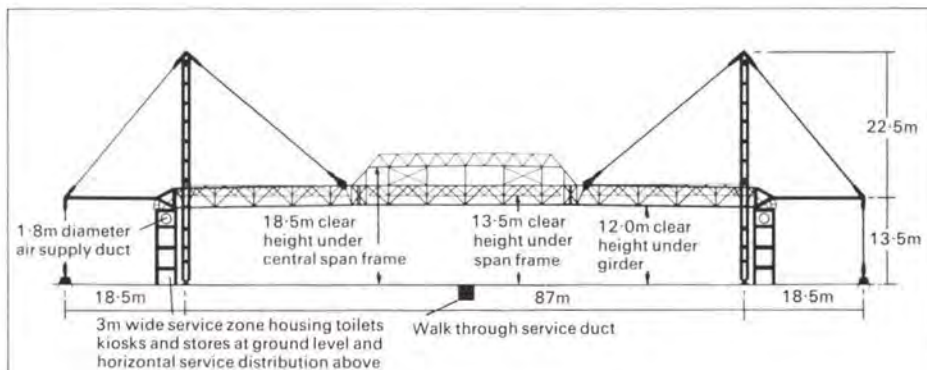

Fig. 5
Short span section through main hall



Fig. 6
Main hall under
construction showing
temporary support
trestle
(Photo: Harry Sowden)

administrative facilities area from the main hall itself. This was done because restaurants, kitchens and office amenities have a high degree of finishing trades, and as such would be on *any* critical path! They had to start early. The facilities building became a two-storey precast concrete frame, with absolutely standard components, obtainable virtually 'off the shelf'. Clearly the overall strategy for servicing the building, and its relationship to the main hall, had to be fixed, and this proved relatively easy to achieve.

The main hall of course provided the biggest challenge. To meet the cost, programme and functional requirements was clearly not going to be easy, and many different alternatives were examined, and many rejected. However, we did establish a set of 'rules' or guidelines which we felt had to be followed

if success was to be achieved. These can be summarized as follows:

- (1) If possible, everything should be simple; not necessarily simple to design or analyze, but simple to build.
- (2) Components should be chosen which would lend themselves to off-site manufacture. Complex site manufacturing was to be avoided.
- (3) Components had to be readily available, if possible from the UK.
- (4) Components in their finished form had to be of a size which would allow simple road transport.
- (5) Components should be interchangeable if possible, so that deliveries out of sequence would not have too serious an effect.



Fig. 7
Mast cap under construction

Fig. 9
Mast and outrigger system

Fig. 10
Pin detail on anchor block

(Photos : Harry Sowden)



7
(6) A design had to be chosen which would allow an early site start on the services installation, and substantial overlapping of the different site trades.

It is fair to say that it is very easy, and perhaps obvious, to list these guidelines, but in practice it is not so easy to stick to them, and much easier to lose sight of them.

The solution

Naturally, in a design process, decisions are often taken in a seemingly strange order, and are often modified by subsequent criteria. The description of the various elements does not in any way imply any order in which they appeared in the design process. In fact, the design was approached as a whole, with structural, servicing, manufacturing and constructional matters all having equal importance within the guidelines.

10
Around the entire perimeter of the building is a service zone which serves several vital functions. It creates a zone for the main above-ground piped services and air ducts, keeping weight and complexity out of the main long-span roofs. It contains all the substantial toilet facilities to cater for 12,000 people. The structure consists of very simple ordinary steel sections fabricated in the works into a vierendeel frame 3m deep and 12m high. Cross-bracing is avoided to allow easy penetration for services, simple fabrication, and to provide the right stiffness or softness of frame to allow thermal movements in the roof structure, while at the same time resisting all the wind forces.

Four air-handling stations were placed, one at each corner, which would again create a separate construction zone. We

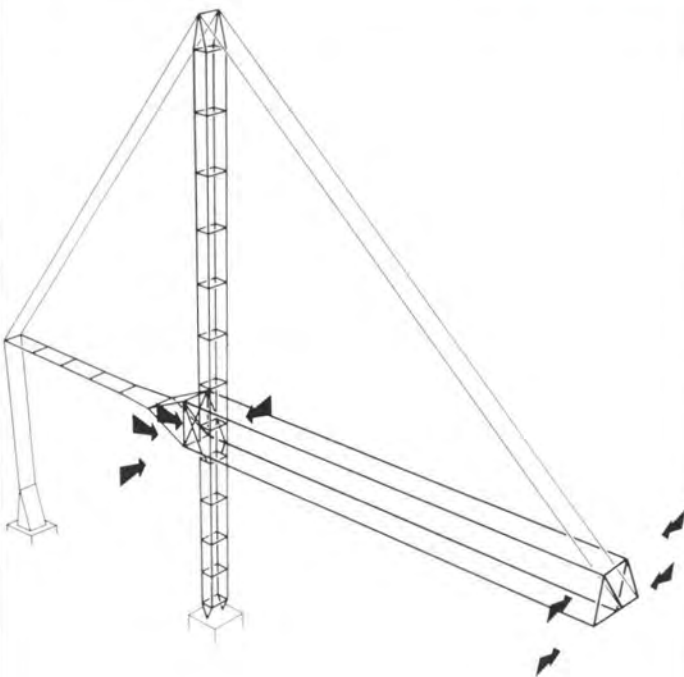

Fig. 8
Analytical model of a single tie system used in non-linear computer analysis. Arrows indicate constraints imposed on the model.

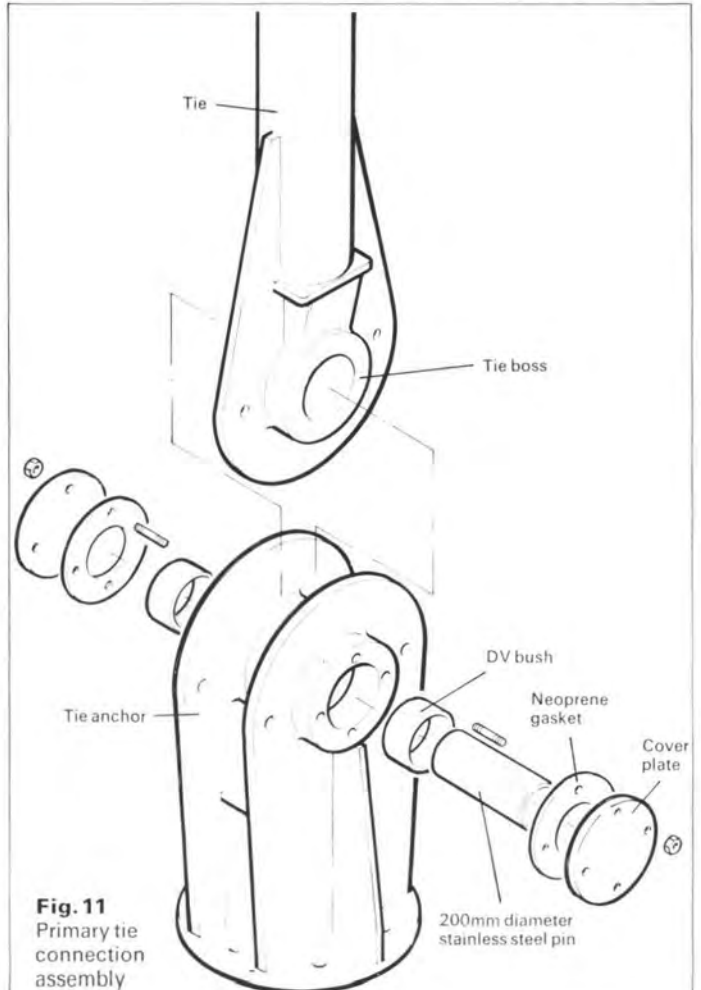

Fig. 11
Primary tie connection assembly

decided to duct air only at the perimeter, but with the facility of allowing change and improvement later in the life of the building. This meant that the exact form of the roof could be chosen from a wider range of materials, including tensile fabric structures. It also meant that a zone could be created round the building which would allow easy access and installation for services without restricting access to the central area for construction of the roof itself.

The final form was chosen in August 1979 and steel placed on order from the scheme design. Double columns around the perimeter were chosen using single and readily available UC sections so that they could start early, and be clad independently of the roof, thus creating a zone for the early installation of services.

The perimeter structure is 'soft'. It is not braced so that it is easily penetrated by the services, and is not so rigid that it attracts overmuch load from thermal movement in the roof, but is sufficiently strong to resist all the wind forces. There are no movement joints, except between the reinforced concrete frame amenity block, and the steel frame hall. Lack of roof weight was such that wind uplift proved to be a significant problem, and was overcome only after wind tunnel tests which showed the code of practice to be unnecessarily conservative in cases of this kind.

The analysis of the structure was done in stages. To begin with, desk-top computers were used to establish the beam, column and frame forces, and the final stage comprised a non-linear analysis on the main frame computer of a single suspension system. This served to give final deflections and confirm the earlier cruder analyses. As a point of interest this final analysis proved worrying at first, as it came at a late stage and cast doubts on the stability of the system. However, it was the program that proved to be wrong, and not the chosen structural solution.

The 3m wide perimeter zone is clad using profiled steel sheeting spanning horizontally to minimize secondary cladding steel. This cladding and the roof to the zone was started early to provide protection from the weather thus allowing an early start to the installation of the services.

The roof structure consists of nine Nodus space frames simply supported on each of their four sides by tubular steel box section trusses, two in each direction, which span across the hall at roughly the third point of each side. The central Nodus frame is placed at a higher level to give increased headroom to the middle of the hall.

The four trusses are supported at their intersection points by tubular steel tension members in pairs, which pass over the top of eight 32m high box section towers, and via extension out-riggers to the trusses into an anchorage of tension piles in the ground. The towers are each four legged, using 450mm x 250mm RHS members to form vierendeel box columns, and are supported on a hinge at the ground level to allow wind and thermal movements at roof level. The tension members are 273mm CHS, delivered in one length and simply fixed at each end via stainless steel pins in low friction seatings. The ties were craned into position, and because of the hinges and flexibility of the towers, proved remarkably easy to position, although causing much effort of design and planning to achieve the eventual simplicity.

Erection

Much thought was given to the erection programme. In some ways it followed an unusual pattern. As previously explained, the perimeter columns were erected first to allow the critical path items of the finishes

Fig. 12
Interior view of corner plant room

Fig. 13
Hall in Arena mode for concert

(Photos : copyright Architects Journal)



and services to start early, but with a small gap to allow the crane access.

The bottom half of each of the eight columns was then erected, and the Nodus frames assembled at ground level below their final position, while at ground level the sprinkler and lighting services were installed. Two of the space frames were assembled outside the hall perimeter, to allow the crane freedom of movement within the hall, and the last frame was placed in position with the crane standing outside the hall.

Temporary trestle columns were erected to

support the main trusses at their intersection points. The trusses were delivered to the site in three lengths of around 30-34m and lifted onto their supports on the perimeter columns and the temporary trestle columns.

The upper halves of the columns were then placed in position, and then the ties were lifted into place and secured via their pin connectors. The ties proved to be very quick and simple to install, and once in position, they were tensioned via Macalloy rods at the roof connections, thus lifting the roof off its temporary trestle column supports. **11**



Once the spaceframes were in position, roof sheeting started, using a profiled steel sheeting perforated in the webs to give acoustic absorption, and the roofing operation was substantially completed before the final tensioning of the support system was undertaken.

By taking this approach, and following the guidelines identified at the outset needed to achieve the programme, the building was completed on time, with the major steelwork sub-contract being completed in the remarkably short period, both at works and on site, of some eight months. Design and construction processes were closely linked and had substantial overlaps. Fabrication off site, which included the final coats of paint leaving only touch up on site, kept the site clear for many other critical path items. In all, the total steel weight used for the structural elements proved to be some 1250 tonnes with the roof itself using a remarkably small amount of 1161 tonnage, being the equivalent of only 106 kg/m².

The services

The plant serving Hall 7 is located in a central energy centre mid-way along the west face of the building. Medium temperature hot water, chilled water and power are supplied to the four corner air-handling plants and the two-storey amenity block via the 3m perimeter service zone.

Medium temperature hot water is provided by two 2500 kw gas fired boilers and chilled water by a single hermetic 500 TR chiller and roof-mounted, induced draught, cooling tower. Constraints on the budget precluded the installation of a second chiller and cooling tower to provide chilled water capacity under maximum load and standby capacity. Space has been provided in the energy centre for the second chiller and allowance made in the roof loading to carry an additional cooling tower.

Power is supplied to the new sub-station, which is an integral part of the energy centre, from an extended 11 kv ring main already serving the site. Distribution from the M V

ancillary areas and local distribution board is via the 3m perimeter service zone. An underground duct connects the energy centre to the walk-through service tunnel under the hall and provides the route for power connections to two 1250 A and one 300 A busbar. This busbar installation enables exhibition power requirements of up to 150 W/m² to be supplied via shallow floor distribution trenches.

The supply of heated or cooled air to the main hall is via 1.8m diameter spirally wound ducts and long throw drum louvres at high level on the east and west sides of the Hall. These ducts are supplied by the four main air-handling plants located at the corners of the hall. Each plant supplies a constant air volume of 30 m³/sec. through a balanced supply extract system. When all plants are in operation, this volume represents four air changes/hour in the main hall under normal conditions. Both supply and extract fans run with a maximum recirculation set at 50%; this can be adjusted manually for particular events. On start-up, recirculation dampers are maintained in the fully closed position until a predetermined temperature of 16 °C is achieved in the Hall. Air is extracted through large louvres in each of the four corners and discharged into the plant rooms which act as exhaust plena.

The two-storey amenity block is served by its own roof-mounted air-handling plant. Only the ground floor has been fitted out under the Hall 7 contract due to financial constraints. Provision has been made in the rooftop plant areas for additional air handling units to serve the first floor when it is completed in the future.

The entire Hall is fully sprinklered to FOC rules' Ordinary Hazard Group 3, and the security systems incorporated in the first phase of the NEC have been extended to cover Hall 7. Generally, security systems have been connected back to the central security suite in Phase I but fire protection systems, air-handling systems and lighting can be controlled/monitored from the Hall Master's office within the Main Hall.

Fig. 14

Aerial view of NEC complex with Hall 7 on left
(Photo: Ted Edwards Photography)

Credits

Client:

National Exhibition Centre Ltd.

Project controller:

Francis C. Graves

Architect:

Edward D. Mills & Partners

Quantity surveyors:

Francis C. Graves & Partners

Main contractor:

R. M. Douglas Construction Ltd.

Steelwork sub-contractor:

Redpath Engineering Ltd.

Mechanical services sub-contractor:

Matthew Hall Mechanical Services Ltd.

Electrical services sub-contractor:

N. G. Bailey & Co. Ltd.

An alternative approach to ultimate limit state design

David Croft

Introduction

Background

Although codes of practice such as *CP110* and *BS449* can be applied more or less directly in most situations that arise in practice, there are occasions when it is necessary to extrapolate the principles of a code to situations which are not covered explicitly. Typical of such cases are:

- (i) Examining existing structures to determine either their safety under current loads or their ability to carry increased loading
- (ii) Structures subjected to types of loading not covered by the code
- (iii) Design of structural elements based on the results of tests on prototypes.

Over the last few years there has been some considerable debate on the application of limit state design methods, particularly in situations not directly covered by *CP110*, for example in geotechnical design. At the same time, *CP110* itself has been undergoing a substantial revision and this has provided the opportunity to include a new section on ultimate limit state design in the draft for public comment which was published early in 1982. In this new section a design method is proposed which will give guidance in these situations.

The basis of the method, which is referred to here as the β -Method, is that the margin of safety to be provided, between the strength of a structural section and the resultant load effect that it has to withstand, should be determined from consideration of the uncertainties in their values.

The β -Method has been calibrated so that it is compatible with *CP110* for the standard load combinations but can be extrapolated to other situations as well, thereby achieving designs with, theoretically at least, similar levels of safety.

The purpose of this article is to describe the method and also to provide additional information on the statistical data used and on the calibration of the method with *CP110*. It should, however, be noted that the method is not limited to *CP110* and can also be applied to other material codes.

Uncertainties in design

In the design of structures there are three principal areas of uncertainty, namely:

- (i) The magnitude and arrangement of the loads
- (ii) The properties of the structural materials
- (iii) The validity of the assumptions made in the calculations.

In *CP110*, allowance is made for these uncertainties by applying partial factors of safety to the characteristic values of the loads and material strengths (except in particular cases such as shear in beams where the factor is applied in effect to the combined resistance of the materials). The material factor γ_m is intended to cover the uncertainties in the resistance of sections. This includes both uncertainties about the material properties and uncertainties about the validity of the assumptions made in strength calculations. The partial factors applied to the loads, γ_f , are intended to cover not only the

uncertainties about the magnitude of the loads but also those relating to the analysis of the structure.

In practice, however, failures are usually associated with gross errors rather than with just extreme values of the principal variables. Such gross errors include, for example:

- (i) Failure to take account of an adverse effect that is significant, e.g. a type of load or combination of loads or a critical temporary condition
- (ii) Calculation errors, e.g. incorrect idealization of the structure, gross arithmetic errors (as opposed to minor inaccuracies)
- (iii) Construction errors, e.g. omission or gross misplacement of reinforcement.

The factors of safety in *CP110* do not cover the effects of gross errors as it would be neither practicable nor economic to do so. The aim should instead be to provide a robust design, i.e. one in which the margin of safety will not be eroded unduly by small changes in the values of the input variables assumed. In this way some reserve of safety will be maintained to cover unforeseen effects in both construction and structural behaviour.

Overall level of safety

A distinction must be made between *factor* and *level* of safety. It is clear that with the partial safety factor approach, the overall factor of safety will vary depending on which type of loading is predominant and whether it is the concrete or steel strength that is governing. It is also important to note that the level of safety, in whichever way it is defined, will also vary from structure to structure.

For example, there is a simplification implied by *CP110* in that the equation

$$R \geq S$$

where

R = function (characteristic strength/ γ_m)

and S = function (characteristic loads $\times \gamma_f$)

is applied to individual critical sections of the structure rather than to the structure as a whole, and the load effect S is usually the worst value obtained from the envelope for a number of different load combinations. Although some allowance for plastic redistribution is permitted by the code, it is necessarily both simplified and conservative and this results in an undefined extra margin of safety.

In addition there is an inherent rounding-up in the design process; structural elements are often grouped for economy in construction, and frequently it is serviceability considerations that govern the design. As a result there will in practice be considerable variation in the level of safety provided. Greater uniformity will not be achieved without considerable extra computational effort.

Characteristic values

It is worthwhile first to consider what we mean by a characteristic value. Although the characteristic values for loads and materials as used in *CP110* form a convenient base to which the engineer may refer, it should be realized that the definitions vary depending on what is being considered.

In *CP110* it is normal to calculate dead loads from the dimensions given on the drawings, using standard unit weights. They can therefore be considered as being the values that are most likely to occur.

Imposed loads are normally taken as the statutory values as given by *CP3 Chapter V: Part 1*. Although not specified, it is often assumed that these values have roughly a 95% probability of not being exceeded. Alternatively, live loads are sometimes calculated directly for specific situations

and these will often be, like dead loads, the values that are most likely to occur.

For wind loads, the characteristic value is usually taken as the load caused by the 50-year return period wind acting in the most adverse direction for the structural member under consideration. Although there is a high probability that the 50-year wind will occur from some direction during the design life of the structure (e.g. 0.63 for a design life of 50 years), the probability that it will occur in a critical direction is somewhat less.

For materials the characteristic value is normally a specified minimum strength. This is theoretically defined as the value below which not more than 5% of the test results should fall.

It follows that the values of the partial factors must take account not only of the variability of the parameters considered, but also of how the characteristic values are defined.

Expected values

When considering the statistical variation of loads and material strengths a more useful value is the *expected* value. For the present purpose this is defined as the best estimate of the worst value that is expected to occur during the design period under consideration. When it is appropriate to determine the expected value by a statistical approach, then for loads that are constant with time (e.g. dead loads) the expected value should be taken as the mean of the population. For loads that vary with time (e.g. live and wind loads) it will usually be necessary to consider both expected maximum and minimum values. The expected maximum value should be taken as the mean of the extreme value distribution corresponding to the design period under consideration, while the expected minimum value will usually be taken as zero. For strengths of structural sections the expected value should be taken as that calculated from the expected in situ material strengths using a calculation method that gives the best fit to the available test data.

The differences between expected and characteristic values for different types of loading are illustrated diagrammatically in Fig. 1.

Worst credible values

Another useful definition when considering the uncertainty associated with a load or material strength is the *worst credible value*. This is the worst value that the designer could realistically believe might occur. It is not necessarily the worst that is physically possible, but rather a value that is very unlikely to be exceeded.

For distributions that are well-behaved and continuous (but not necessarily normal) the worst credible value can be defined quantitatively as the value corresponding to three standard deviations from the mean. (For a normal distribution this would correspond to a probability of about 0.1%).

Alternatively the worst credible value can be regarded as representing the limit of the variability that will be taken account of in the design and as such it becomes, in effect, a cut-off value.

It should be emphasized at this point that the standard deviation as used here does not refer to the frequency distributions of measured data but rather to the uncertainty concerning the value in a parent population (as in the case of soil samples) or of some event in the future, (as in the case of loading), or of construction quality (as in the case of structural materials). In many cases, however, these cannot be measured directly and some engineering judgement must be applied in order to quantify them.

It is therefore, suggested that, in the absence of more precise information, the standard deviation of a variable can be conveniently determined by first assessing the expected and worst credible values and then taking one third of the difference.

Proposed design method

The principle of the β -Method is that the expected magnitude of the margin of safety should be proportional to the uncertainty in its value. This requirement can be expressed in mathematical form as follows:

$$\bar{R} - \bar{S} \geq \beta \sqrt{(\sigma_R^2 + \sigma_S^2)} \quad (1)$$

where

\bar{R} is the expected section resistance

\bar{S} is the expected resultant load effect

σ_R σ_S are the standard deviations of R and S and

β is a constant dependent on the level of safety required.

It will be noted that Equation (1) bears a strong resemblance to second order probability methods which are widely covered in the literature¹. It must be emphasized, however, that no attempt should be made to infer a 'probability of failure' as, for the reasons, such as the uncertainties in the assumptions and the effects of gross errors, as discussed above, the result would be unrealistic. The method should instead be regarded as a means of extrapolating existing experience rather than as a probabilistic exercise.

By expressing the standard deviations in terms of coefficients of variation, equation (1) can be solved for \bar{R} thus:

$$\bar{R} = \frac{\bar{S}[1 \pm \beta \sqrt{(v_R^2 + v_S^2 - \beta^2 v_R v_S^2)}]}{1 - \beta^2 v_R^2} \quad (2)$$

where $v_R = \sigma_R/\bar{R}$

and $v_S = \sigma_S/\bar{S}$

Equation (2) can now be expressed in terms of R_u , the required ultimate resistance

calculated in accordance with CP110, thus:

$$R_u/\bar{R} = \frac{[1 \pm \beta \sqrt{(v_R^2 + v_S^2 - \beta^2 v_R v_S^2)}]}{1 - \beta^2 v_R^2} \quad (3)$$

In order to use Equation (3) it is necessary to determine appropriate values for v_R and v_S , the ratio of the expected value \bar{S} to the characteristic value S_k and also the ratio R_u/\bar{R} . The value for β can then be found by calibration against the standard load combination given in CP110. These steps are described in the sections following.

First, however, it is worth stating some assumptions which are implicit in the method as follows:

- (i) The method assumes a linear relationship between the primary load variable and its effect in the member under consideration. While this is reasonably true for most structures subjected to dead, live and wind loads, there may be situations when this assumption is not valid.
- (ii) In Equation (1) there is no explicit allowance for the uncertainties in the analysis of the structure as this would be dependent on particular circumstances. It is implied that this uncertainty is relatively small compared with the other uncertainties. When this is not the case, it should be allowed for by making suitably conservative assumptions in the analysis.
- (iii) When the method is applied in situations where there is a high degree of certainty regarding the primary variables, then particular care must be taken in assessing possible second-order effects, as these may become significant in such situations.

Loads

Dead loads

It follows from the definition that the characteristic dead load is the expected value. It is reasonable to assume a normal distribution for variations about that value. For the coefficient of variation a figure of 5% is suggested, thus:

$$\bar{S}/S_k = 1.0 \quad v_S = 0.05$$

These figures imply a probability of 0.1% that the dead load will differ from its expected value by more than 15%. This is considered to be a reasonable figure.

Live loads

It should be noted that the coefficient of variation v_S refers here to the uncertainty in the load over the whole design period and not just simply to the results from surveys carried out on existing structures. It should take account of the way in which the structure being designed will be used and also possible changes in occupancy.

As already noted above, live loads are of two types:

- (i) Statutory loads taken, for example, from CP3: Chapter V: Part 1.
- (ii) Loads that are calculated directly e.g. plantroom loads.

For statutory loads, the characteristic values are taken as those given by CP3: Chapter V. As already mentioned, these are traditionally assumed to have a 95% probability of occurrence.

As regards the shape of the probability function, the data available indicates that the general form is distinctly skew as shown in Fig. 1. This is examined in more detail in Appendix A, where it is concluded that

$$\bar{S}/S_k = 0.55 \quad v_S = 0.50$$

It must however be noted that the data referred to in Appendix A relate only to

typical office conditions and the above statistical parameters may not be applicable to other types of live loading. However, in most cases there will be some practical limit to the variability that need be considered in the design as there is, in practice, usually some legal responsibility on the part of the owner (or at least an economic interest) to ensure that the stipulated loads are not exceeded.

The function of the partial load factor for live loads is therefore to provide a margin of safety for possible overload that could reasonably occur by accident, and beyond which the designer of the structure is not responsible. In situations where this argument does not apply, then this should be allowed for explicitly in the choice of characteristic load rather than by the partial safety factor.

It is therefore suggested that the above values are reasonable values generally for all statutory loading.

For live loads that are calculated directly, the characteristic load will be the expected value. CP110 does not however distinguish between the different types of live load. It can be shown by reference to Equation (7) below that $\gamma_f = 1.6$ implies values as follows:

$$\bar{S}/S_k = 1.0 \quad v_S = 0.12$$

Wind loads

Wind loads are normally defined in terms of the Characteristic Wind Load which is usually taken as the load caused by the 50-year return period wind acting in the most adverse direction for the structural member under consideration. In deriving load factors, account must therefore be taken of the following:

- (i) The nature of wind data is such that the value of the 50-year return period wind normally available is that for all wind directions combined, i.e. it is that wind which has an annual probability of 2% of occurring from any direction.
- (ii) During the design lifetime of the structure it is probable that winds in excess of the 50-year return period wind will occur. For example, if the design lifetime is taken as 50 years there is a 63% probability that the 50-year return period value will be exceeded during that time and for longer design lifetimes this probability will be even greater.

A useful approach therefore is to consider load effects (which take account of the variation with wind direction, for example, of an axial force or bending moment in a particular column) rather than the load itself and to determine the probability of occurrence within a specified design lifetime.

In Appendix B, an analysis of the statistics of wind loading is presented from which it is concluded that, for wind loads in the UK,

$$\bar{S}/S_k = 0.95 \quad v_S = 0.2$$

Section strengths

Partial material factors

In order to deduce a value for R_u/\bar{R} it is necessary to take account of the values of γ_m specified in CP110. For the ultimate limit state these are as follows:

Concrete in flexure and compression	1.5
Steel	1.15
Concrete in shear	1.25

Values of γ_m for other situations, such as torsion, bearing or maximum shear stress (CP110, Table 6) have not been derived with precision. They are basically lower bounds to the available data. The resulting design values are thus likely to be conservative relative to a more rigorous treatment. The values of γ_m implied in such cases may be assumed to be at least 1.5.

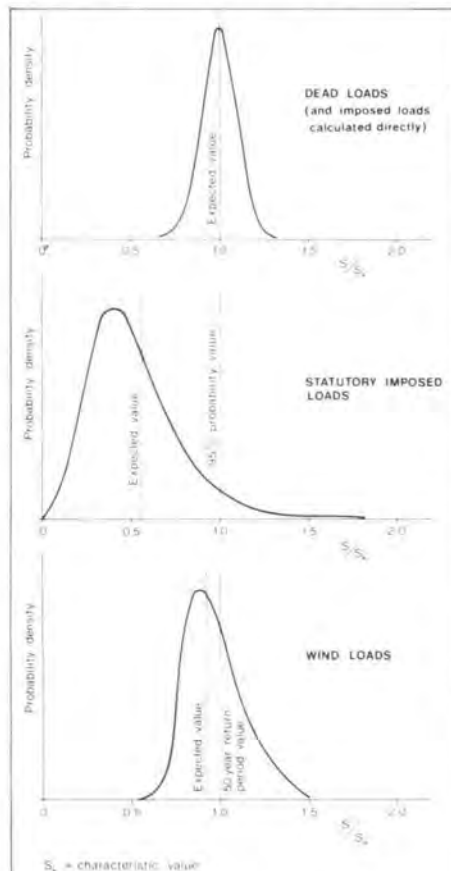

Fig. 1 Typical probability distributions

These partial safety factors are intended to take account of the following:

- (i) The variation in strength of the concrete and reinforcement as measured by test specimens
- (ii) Possible differences between the strength of the concrete in the structure and that derived from the test specimens.
- (iii) Possible variations in section strength as a result of construction tolerances
- (iv) Imperfections in the theories and formulae used in the prediction of strength.

The values of the materials factors take account of the importance of the limit state under consideration and the possible modes and consequences of failure.

The partial material factors are in general applied to the characteristic strengths of the concrete and steel. In the case of shear (CP 110, Table 5), however, the section resistance is a function not only of the concrete cube strength but also of the interaction of the concrete with the longitudinal reinforcement, dowel action, aggregate interlock, etc., the effects of which are not fully understood. The partial factor is in this case applied to the combined section resistance obtained from an empirical formula based on test data.

Assumed variabilities

The cases of bending, shear and axial compression are examined in Appendix C and the results are shown plotted in Fig. 2 in terms of R_u/\bar{R} against v_R . Reference to Equation (3) indicates that to be conservative an upper bound value of R_u/\bar{R} is required and the following has been taken

$$R_u = \bar{R} (1 - 2.75v_R) \quad (4)$$

Calibration against CP110

Using the values of the variabilities described above the method has been calibrated against the standard loading conditions required by CP110 which in the new version are as shown in Table 1 below.

Table 1: Values of γ_f for the ultimate limit state

Load combination	Load type		
	Dead	Live	Wind
Dead + Live	1.4 or 1.0	1.6 or 0	—
Dead + Wind	1.0	—	1.4
Dead + Live + Wind	1.2	1.2 or 0	1.2

Where alternative values are given, the more onerous for the section under consideration should be taken. For combinations of dead, live and wind loads the values of \bar{S} and v_s can be obtained from

$$\bar{S} = G_k(\bar{G}/G_k) + Q_k(\bar{Q}/Q_k) + W_k(\bar{W}/W_k) \quad (5)$$

$$v_s = \sqrt{(\sigma^2_G + \sigma^2_Q + \sigma^2_W)/\bar{S}} \quad (6)$$

$$\text{and } \sigma_G = G_k(\bar{G}/G_k)v_G \text{ etc.}$$

where \bar{G} , \bar{Q} , \bar{W} are the expected dead, live and wind loads respectively.

and σ , v denote the corresponding standard deviations and coefficients of variation.

In applying Equation (3) to load combinations involving wind loads a reduction factor of 1.25 has been applied to R_u to allow for the overstress that is acceptable for this type of loading. The traditional justification for this reduction is:

- (i) The enhanced strength of the materials particularly of concrete, under transient loading
- (ii) Allowance for the load-carrying capability of non-structural elements such as cladding and internal partitions.

There is also the possibility, as discussed in Appendix B, that the winds corresponding to very long return periods which have a significant effect on the calculated wind load variability may be overestimated by extreme value distributions fitted to the available data.

The conclusion of this calibration exercise is that the current partial factors in CP110 when taken in conjunction with the variabilities described above, are compatible with a value of β equal to 4.8.

It is also found, when applying Equation (3) in conjunction with Equation (4), that sufficient accuracy can be achieved by assuming a constant value $v_R = 0.1$.

Combining Equations (3) and (4) and substituting for β and v_R :

$$R_u \geq 0.94\bar{S} [1 \pm 4.8\sqrt{(0.01 + 0.77v_s^2)}] \quad (7)$$

where

R_u is the design ultimate resistance
 \bar{S} is the expected resultant load effect
 v_s is the coefficient of variation of the resultant load effect.

Equation (7) is shown plotted in Fig. 3. For large values of v_s , Equation (7) reduces to

$$R_u \geq 0.94\bar{S} (1 + 4.21v_s) \quad (8)$$

In applying these equations, σ_s is taken as positive always. Normally \bar{S} and v_s will also be positive but cases can arise when both become negative. This implies a situation in which, with expected values, no resistance is required but structural capacity is necessary to allow for the uncertainty.

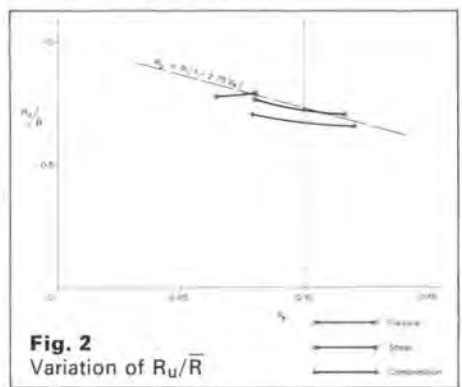

Fig. 2
Variation of R_u/\bar{R}

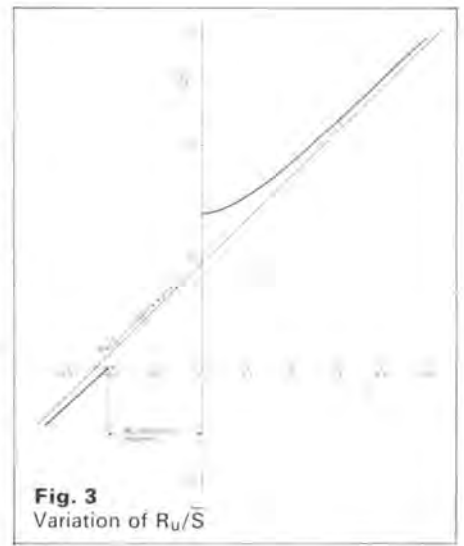

Fig. 3
Variation of R_u/\bar{S}

Fig. 4 shows a diagrammatic comparison of the values of R_u given by CP110 and Equation (7) over the complete range of dead: live: wind load ratios for the case when dead load is adverse. Similar diagrams can be produced for the beneficial dead load case.

The ratios of CP110 to the proposed method are given in Tables 2 and 3.

A negative value indicates resistance required by β -method but not by CP110.

For the adverse dead load condition good agreement is evident, bearing in mind that it is not possible to exactly fit a curved surface to a set of planes such as shown in Fig. 4.

With the beneficial dead load condition the agreement is not as good and in fact has been made worse by the change in the dead load factor from 0.9 to 1.0 in the latest draft of CP110. It is apparent that the worst discrepancies occur when the factored-up wind and live loads just exceed the factored-down dead loads and the resulting level of stress will then be quite low. Nevertheless the conclusion must be that CP110 is less conservative for this condition relative to the more common case of adverse dead load.

Application of the method

General

The method can be applied in a number of ways, either directly or, alternatively, to derive sets of partial factors as described below. It must however be applied with some caution and attention is particularly drawn to the assumptions implied by the method as discussed above.

Care must also be taken in deciding whether or not variables are statistically dependent as the standard deviation of the sum of two dependent variables is the sum of their standard deviations and not the root-sum-square as would be the case if they were independent.

Table 2

RATIO: CP110/ β -METHOD

Dead Load Adverse

	100%DL	0.98					
		1.07	1.04				
		1.09	1.11	1.02			
		1.07	1.08	1.08	1.00		
	1.02	1.04	1.07	1.02	1.00		
100%LL	0.98	0.98	1.03	1.02	0.95	0.99	100%WL

Table 3

RATIO: CP110/ β -METHOD

Dead Load Beneficial

	100%DL	None					
		None	None				
		0.32	-7.86	-0.38			
		0.94	0.63	0.64	0.88		
	0.98	0.96	0.96	0.90	0.97		
100%LL	0.98	0.98	1.03	1.02	0.95	0.99	100%WL

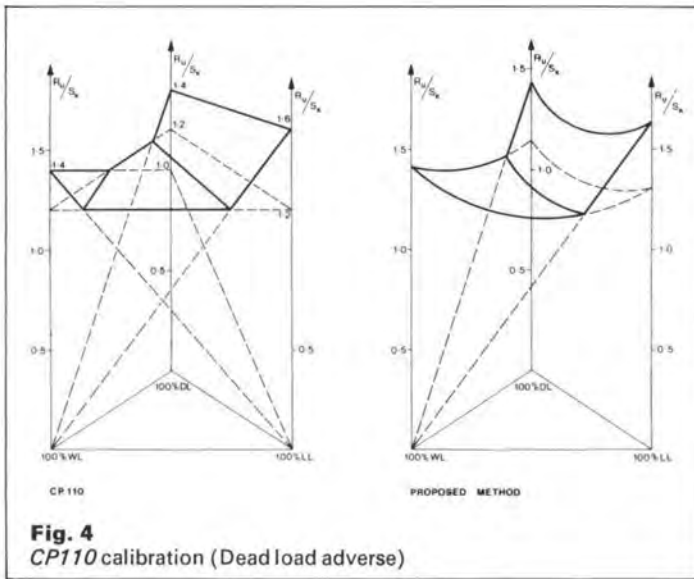

Fig. 4
CP110 calibration (Dead load adverse)

When this approach is used, particular attention should also be given to the serviceability limit states as it is possible that the 'deemed-to-satisfy' provisions (e.g. the limiting span/depth ratios) in CP110 may not be adequate.

Specific application

The method can be applied directly to specific situations. It must, however, be realized that the results will be specific to those situations.

Derivation of partial load factors

When assessing appropriate partial factors using this procedure, values of \bar{S}/S_k and v_s should be assessed for the particular loading being considered. The standard values should be used for any types of loading for which specific data have not been collected (for example, if data on the particular imposed load to be used were collected, new values would be derived for \bar{S}/S_k and v_s from these data but the values above would be used for dead load and wind load).

Having selected appropriate loading parameters, Equation (7) can be used to generate values of R_u/\bar{S} covering the full range of ratios, for example, of dead: imposed: wind load, that is of practical interest.

Values of γ_f for each load type and for different combinations can then be determined by trial and error so that a 'best but conservative fit' is obtained over the whole range.

Derivation of partial material factors

Values for γ_m can be derived in an analogous method to that employed for γ_f but using Equation (4).

Formulae, derived from design equations, relating the overall variability, v_R , to the variabilities of the various parameters, can be derived explicitly in some cases. In more complex situations it may be more convenient to assess v_R by use of a 'Monte Carlo' approach.

As for γ_f , the approach should be to obtain values of R_u and v_R over the expected range of values of the various parameters involved in the strength prediction and then assess values for γ_m which will give a 'best fit' to Equation (4). Whenever possible the standard γ_m values given in CP110 should be used for parameters for which no explicit assessment of variability has been made.

Design strengths from prototype tests

This approach can also be used to determine ultimate strengths from the results of tests on specific elements (for example, the design by test of a particular precast unit). In such cases a sufficient number of tests for a reasonable estimate of the coefficient of variation to be made should be carried out by

engineers with relevant experience using suitable equipment. The resulting strengths will apply only to the particular unit considered.

Appendix A:

Statistics of live loads

For the probability distribution as shown in Fig. 1 for statutory live loads a convenient function is the Fisher-Tippett Type 1 extreme value distribution in which the probability P of a value S not being exceeded during the lifetime of the structure is given by

$$P = e^{-e^{-\alpha(S-U)}} \quad (9)$$

in which U is the mode and $1/\alpha$ is the dispersion.

Rearranging (9)

$$S = U - 1/\alpha \log_e \log_e (1/P) \quad (10)$$

For the Type 1 distribution it can be shown² that the mean \bar{S} and standard deviation σ are given by

$$\bar{S} = U + \frac{0.577}{\alpha} \quad (11)$$

$$\sigma = \frac{1.282}{\alpha} \quad (12)$$

Assuming $P = 0.95$ when $S = S_k$, then combining (10), (11) and (12)

$$\bar{S}/S_k = \frac{\alpha U + 0.577}{\alpha U + 2.97} \quad (13)$$

$$v_s = \sigma/\bar{S} = \frac{1.282}{\alpha U + 0.577} \quad (14)$$

It is apparent that \bar{S}/S_k and v_s depend solely on the value of αU . In determining an appropriate value for αU it is important to consider the shape of the distribution in the upper tail, i.e. for values in excess of S_k . Data relating to office loading is available in Reference 3 in which it is argued that account must be taken not only of the measured variations but also of the effects of change of occupancy.

In Fig. 5, which has been reproduced from Reference 3, office loading intensities for 95%, 99% and 99.9% probabilities are shown plotted against area loaded for the case after 12 occupations and Fig. 6 shows the ratios averaged for all areas to the 95% value, plotted against cumulative probability. Superimposed on the latter are the curves for $\alpha U = 1, 2$ and 3 and in the range of particular interest (i.e. \bar{S}/S_k in the range 1.3–1.6) good agreement is shown for values of αU between 2 and 3. Substitution in Equations (13) and (14) suggests that it would be reasonable to take the following values:

$$\bar{S}/S_k = 0.55 \quad v_s = 0.5$$

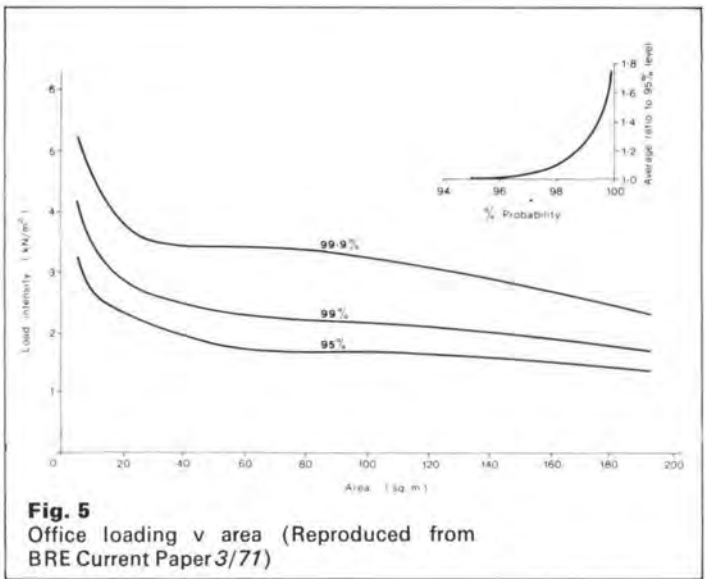

Fig. 5
Office loading v area (Reproduced from BRE Current Paper 3/77)

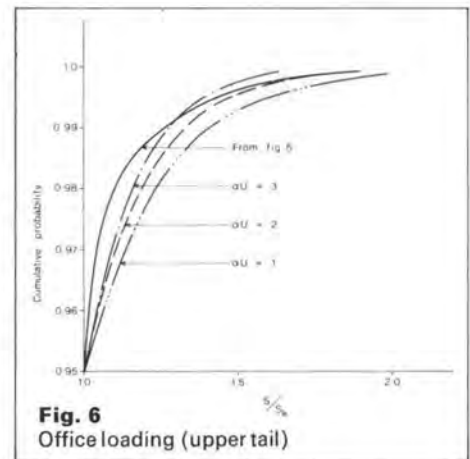

Fig. 6
Office loading (upper tail)

Appendix B:

Statistics of wind loads

Extreme values of wind can be expressed in terms of the Fisher-Tippett Type 1 extreme value distribution in which the probability P_1 of a windspeed V not being exceeded in any one year is given by:

$$P_1 = e^{-e^{-\alpha(V-U)}} \quad (15)$$

in which U is the mode and $1/\alpha$ is the dispersion. The product αU is a function of the wind climate and the values of S_3 given in CP3: Chapter V: Part 2 Fig. 2, in fact, imply a constant value $\alpha U = 9$.

If now the 360° arc is divided into n equal sectors (and assuming these are stochastically independent), then if the proportion of the extreme winds that occur in a sector at angle θ is $g(\theta)$ then the probability P_2 of a velocity V not being exceeded in that sector in any one year is given by

$$P_2 = P_1^{g(\theta)} \quad (16)$$

The probability of V not occurring in N years (again assuming individual years are stochastically independent) in this sector is given by

$$P_3 = P_2^N = e^{-Ng(\theta)e^{-\alpha(V-U)}} \quad (17)$$

Defining the 'characteristic load effect' as the load effect when the 50-year return period wind is acting in the most adverse direction ($\theta = 0$) for the member under consideration then the load effect S due to wind velocity V acting at an angle θ is given by

$$S = (V/V_{50})^2 S_k f(\theta) \quad (18)$$

in which the function $f(\theta)$ has a value between unity (when $\theta = 0$) and zero.

Putting $x = V/V_{50}$

then the total probability P of a load effect S occurring with winds from all directions in N years is given by

$$P = 1 - e^{-N \sum_{i=1}^n g(\theta_i) e^{-\alpha U - \alpha V_{50} x_i}} \quad (19)$$

$$\text{where } x_i = \sqrt{\left[\frac{S/S_k}{f(\theta_i)} \right]} \quad (20)$$

The value of αV_{50} can be found from Equation (15) thus

$$\begin{aligned} \alpha V &= \alpha U - \log_e \log_e (1/P) \\ \alpha V_{50} &= \alpha U + 3.9 \end{aligned} \quad (21)$$

Equation (19) which represents a cumulative probability function (CPF) can be evaluated numerically and differentiated to obtain the corresponding probability density function (PDF) and typical results are shown in Fig. 8.

In order to evaluate Equation (19) it is necessary to make some assumptions for the various parameters.

For αU a value $\alpha U = 9$ has been taken as this corresponds to general conditions in the UK. However, in evaluating Equation (19) it was found that the upper tail of the PDF is quite sensitive to large extreme wind speeds even though the implied probability is very low while it must be remembered that the available wind data are based on, at most, 70 years of readings. An upper limit of a 1000-year return period wind has therefore been taken (which corresponds to $S/S_k = 1.52$) as it is suggested that further extrapolations cannot be justified. Indeed, it is possible that even 1000 years is excessive.

For the design lifetime of the structure, values of $N = 50$ and 100 years have been taken.

For the function $g(\theta)$ two cases have been considered

Case I Equal probability of wind from all directions, i.e. $g(\theta) = 1/n$

Case II All the extreme winds occur in a 90° sector, i.e.
 $g(\theta) = 4/n$ for $-45^\circ < \theta < 45^\circ$
 $= 0$ otherwise

The function $f(\theta)$ indicates how the load effect varies with angle from the critical wind direction. This will clearly depend on the shape of the building as well as structural configuration but can be conveniently represented by a cosine function thus:

$$f(\theta) = \cos^m \theta \text{ for } -90^\circ < \theta < 90^\circ \\ = 0 \text{ otherwise}$$

For example, for a circular building with a circular wind-resisting core the vertical

stress due to bending under wind loads will be given by $m = 1$. For other situations m will be either greater or less than unity, the latter being more conservative. Values of $m = 1$ and 0.5 have therefore been taken.

The functions $f(\theta)$ and $g(\theta)$ are illustrated in Fig. 7.

Having obtained the PDF, the mean and standard deviation can be obtained and selected results are given in Table 4.

Table 4

N	$g(\theta)$	m	\bar{S}/S_k	v_s
50	Case I	1.0	0.818	0.210
100	Case I	1.0	0.911	0.192
50	Case I	0.5	0.860	0.203
100	Case I	0.2	1.007	0.177
50	Case II	1.0	1.005	0.174
50	Case II	0.5	1.041	0.171
100	Case II	0.5	1.140	0.149

There are however other uncertainties in the determination of the wind load acting on buildings besides that just due to the estimation of extreme wind speed, particularly for example in the variation of wind speed with height and in the force and pressure coefficients. Little information, however, is available at present regarding the accuracy of the values given in *CP3: Chapter V*, but opinion appears to be that they are generally somewhat on the safe side. These uncertainties would thus tend to reduce \bar{S}/S_k and increase v_s .

Taking all these factors into account it seems not unreasonable for the present purpose and for design lifetimes in excess of 50 years to take the following values:

$$\bar{S}/S_k = 0.95 \quad v_s = 0.2$$

For design periods shorter than 50 years some reduction in load appears justifiable and the following have been obtained by comparing the values for $N = 50$ years and less.

Table 5

N	\bar{S}/S_k	v_s
50	0.95	0.2
20	0.834	0.223
10	0.747	0.240
5	0.663	0.257

It is interesting to note that if the worst credible is taken as corresponding to three standard deviations then it corresponds

almost exactly to the 1000-year wind. This as already argued above would seem intuitively to be quite reasonable.

It should be noted that these values have been derived from UK wind data and may not be directly applicable to other wind climates (i.e. for other values of αU). In the absence of other information it is therefore suggested that v_s in these cases can be determined from consideration of the 50 and 1000-year values.

Appendix C

Section strengths

In this appendix, formulae are presented relating the ultimate section resistance R_u as given by *CP110*, the expected value R and the standard deviation of R to the variabilities of the constituent parameters for the cases of flexure, shear and direct compression. The results for the practical ranges of reinforcement percentages are shown plotted in Fig. 2.

(i) Flexure

For members in bending the expected and design values of the resistance moment are given by

$$\bar{R} = (1 + 1.64v_s) A_s f_y d \left[1 - 0.82r \frac{(1 + 1.64v_s)}{\phi} \right] \quad (22)$$

$$R_u = \frac{A_s f_y}{\gamma_{ms}} d \left[1 - 0.82r \frac{\gamma_{mc}}{\gamma_{ms}} \right] \quad (23)$$

where

$$r = \frac{A_s}{bd} \frac{f_y}{f_{cu}}$$

The standard deviation of R is given by

$$\sigma_R = \bar{R} \sqrt{\left[v_s^2 + \left(\frac{0.82r}{1 - 0.82r} \right)^2 (v_c^2 + v_s^2 + v_m^2) \right]} \quad (24)$$

where v_s is the coefficient of variation of the steel strength (taken as 0.08).
 v_c is the coefficient of variation of the in situ concrete strength (taken as 0.12).
 ϕ is the ratio of the expected in situ concrete strength to the characteristic strength.
 v_m is the coefficient of variation of the modelling formula for the concrete stress block (taken as 0.15).

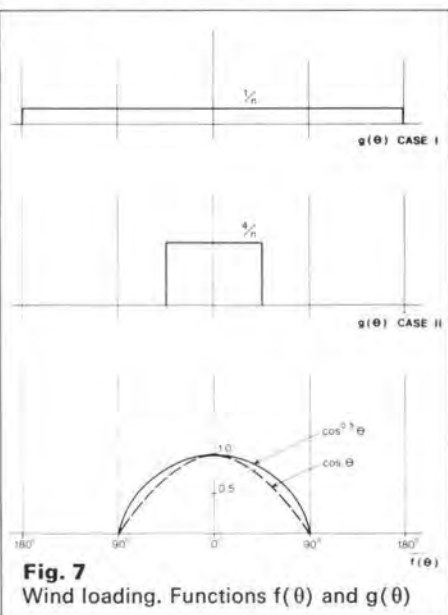

Fig. 7
Wind loading. Functions $f(\theta)$ and $g(\theta)$

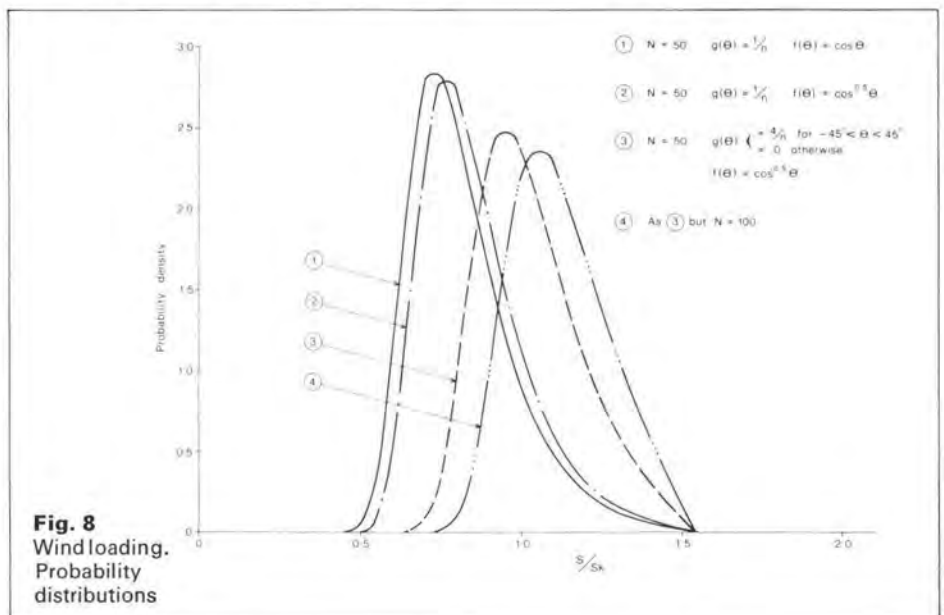

Fig. 8
Wind loading. Probability distributions

Taking the expected in-situ strength to be $0.85 \times$ expected cube strength and the expected cube strength to be $1.2 f_{cu}$.

$$\phi = 0.85 \times 1.2 = 1.02$$

(ii) Shear

For beams in shear the expected and the design resistance can be expressed in the form:

$$\bar{R} = 0.27 \sqrt[3]{\left[\frac{100A_s}{bd} \phi f_{cu} \right] + \gamma_{sv} (1 + 1.64v_s)} \quad (25)$$

$$= \bar{R}_c + \bar{R}_{sv}$$

$$R_u = \frac{0.27}{\gamma_m} \sqrt[3]{\left[\frac{100 A_s}{bd} f_{cu} \right] + \frac{\gamma_{sv}}{\gamma_{ms}}}$$

where $\gamma_{sv} = \frac{A_{sv}}{S_v b} f_y$

and \bar{R}_c and \bar{R}_{sv} represent the contributions of the concrete and shear reinforcement respectively.

The standard deviation of R is given approximately by

$$\sigma^2_R = \bar{R}_c^2 [v_m^2 + (v_c/3)^2] + \bar{R}_{sv}^2 v_s^2 \quad (27)$$

where v_s, v_c, ϕ are as defined above for flexure

v_m is the coefficient of variation of the modelling formula for concrete beams in shear (taken as 0.10).

(iii) Direct compression

For columns in direct compression Fig. 1 of CP110 implies that the concrete stress at failure is limited to $0.67f_{cu}$. When, however, the strain is constant across the section it is reasonable to assume a higher expected value equivalent to the cylinder strength (taken here as $0.8f_{cu}$). The expected and design section resistance expressed in terms of average stress are then given by:

$$\bar{R} = 0.8f_{cu} \phi + \frac{A_s}{bh} f_y (1 + 1.64v_s) \quad (28)$$

$$= \bar{R}_c + \bar{R}_s$$

$$R_u = \frac{0.67 f_{cu}}{\gamma_{mc}} + \frac{A_s}{bh} \frac{f_y}{\gamma_{ms}} \quad (29)$$

The standard deviation of R is given approximately by

$$\sigma^2_R = \bar{R}_c^2 v_c^2 + \bar{R}_s^2 v_s^2 \quad (30)$$

where v_c, v_s, ϕ are defined above.

A lower value for $\phi = 0.85$ has been taken in this case to allow for the reduction in concrete strength that is acknowledged to occur in columns.

Acknowledgements

Much of this material has been prepared in collaboration with a number of other people. The author is particularly grateful for the guidance and criticism given by Drs. G. Somerville and A. Beeby of C & CA, G. Armer and J. Moore of BRE and Brian Simpson, Jack Pappin and Robin Whittle.

References

- (1) COMITE EURO-INTERNATIONAL DU BETON and FEDERATION INTERNATIONALE DE LA PRECONTRAINTE. Common unified rules for different types of construction material. CEB, 1976.
- (2) BENJAMIN, J. R. & CORNELL, C. Probability, statistics and decision for civil engineers. McGraw-Hill, 1970.
- (3) BUILDING RESEARCH ESTABLISHMENT. *Current Paper 3/71*. Floor loadings in office buildings—the results of a survey. BRE, 1971.

The shear clauses for reinforced concrete in CP 110

Robin Whittle

History

The origin of the shear clauses in CP 110 centred on the work of the Shear Study Group in the mid-1960s. The Institution of Structural Engineers published their report 'Shear strength of reinforced concrete beams' in 1969⁵. It made recommendations about permissible shear strength in ultimate limit state terms for beams, based on the analysis of many tests carried out all over the world.

This report compared results of work carried out by Dr Regan at Imperial College, London, with research work from other parts of the world and presented a proposal for the beam shear clauses in CP 110.

The Research Division of the Cement and Concrete Association was also closely linked to the work of the Shear Study Group and under Dr Rowe's direction produced many research reports and professional papers which have added a vital contribution of knowledge and back-up to the shear clauses of the code. In fact the early drafts of the design sections of CP 110 were produced almost entirely by the C & CA.

Since its first publication in 1972 the code continued to be influenced by more recent research work. The main sources of this in the UK have been Dr Taylor at the C & CA, Dr Regan of the Polytechnic of Central London who has extended his researches on flat slabs, and Professor Long who, at Queen's University, Belfast, has carried out considerable work on the structural behaviour of slabs.

Background to the shear clauses

General

The code committee (BLCP 80) spent much time examining the clauses proposed by the C & CA to assess the likely effect they would have on the design of new structures. This was complicated by the fact that they were written

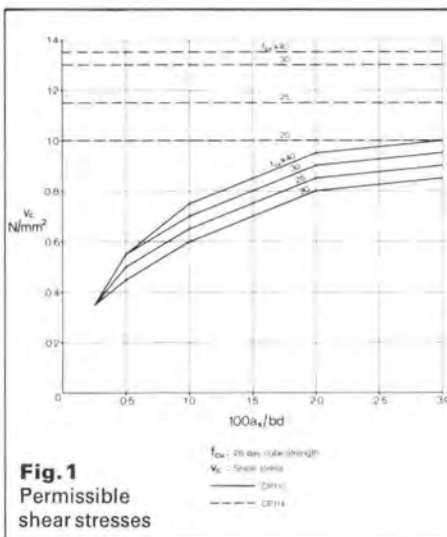

Fig. 1 Permissible shear stresses

for the ultimate limit state in partial safety factor format in addition to which, the results of new research were introduced in these clauses.

The report of the Shear Study Group proposed a table of permissible shear stresses for varying percentages of tension reinforcement and a range of different concrete strengths. In general this gave a large reduction on the permitted stresses compared with CP 114, as shown in Fig. 1.

In accepting these proposals it was realised how important aggregate interlock and dowel action were to the shear resistance. Tests had been carried out by Dr Taylor to quantify this^{7,9}. He showed that for a typical beam the relative proportions of the three mechanisms of carrying shear were:

Compressive zone	20 – 40%
Aggregate interlock	33 – 55%
Dowel action	15 – 25%

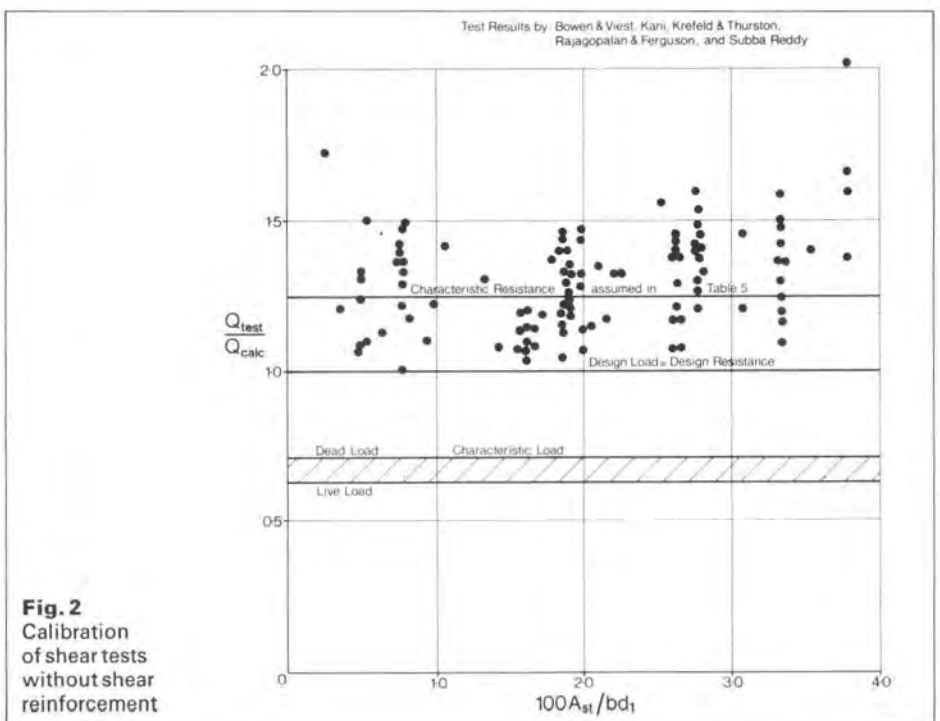

Fig. 2 Calibration of shear tests without shear reinforcement

In order to assist with the assessment, one or two organizations, including Ove Arup and Partners, became involved with design checks. These not only helped to find inconsistencies but also exposed one or two major problems which had still to be solved.

One rather unwelcome discovery rather late in the preparation of the final draft was that the values in Table 5 were not based on the correct definition for material strengths as given in CP 110. This stated that the characteristic strength was that strength below which not more than 5% of the test results fall. In the case of the shear results they had been based on the mean value of the test results as shown in Fig. 2. In order to achieve the correct definition the values of Table 5 should have been reduced by 20%. However, there was strong resistance within the code committee to reduce them further, in the knowledge that they were already much lower than the CP 114 values. A compromise was reached in that for beams a minimum percentage of links was always required which was not accounted for in Table 5. For single and two-way slabs, shear was unlikely to be a design criterion, but for flat slabs not only was shear likely to be critical but the consequence of failure at one column could lead to progressive collapse. Hence for flat slabs a reduction of 20% on permitted shear strength was agreed.

Beams

A number of important conclusions resulting from the report of the Shear Study Group were in direct contradiction to CP 114. These were included in the clauses for beams in CP 110:

- (a) The shear resistance of beams without shear reinforcement was closely related to the amount of tension reinforcement present.
- (b) The shear resistance of beams without shear reinforcement was much less than that assumed by CP 114. For low percentages of tension reinforcement it could be less than half that assumed by CP 114.
- (c) The shear resistance of beams with shear reinforcement still mobilized the full concrete shear strength. CP 114 assumed no concrete shear strength with shear reinforcement. This was unnecessarily conservative.

A further conclusion concerned concentrated loads close to supports. The results of tests with point loads on simply-supported beams⁵ showed that the shear resistance reduced to a minimum when the point load reached a position about three times the effective depth from the face of the support, as shown in Fig. 3. The proposal for CP 110 was conservative and allowed the shear resistance to be increased by the ratio of $2d/a$ for point loads close to supports. For such conditions the failure plane could become very steep and vertical shear links ineffective. Corbels were a prime example of this, where the point load could be very close to the supporting structure. Horizontal links were in this case much more appropriate than vertical ones, as shown in Fig. 4.

A 'true' shear failure may be considered as impossible since concrete is as strong in shear as in compression. However, conditions may be such that the failure plane is forced to be very steep. This can cause web crushing in beams and, even when using shear reinforcement, there should be a limit to the applied shear. In CP 114 this was restricted to four times the permissible concrete shear resistance. In CP 110 it was related to test results^{5,22}. Table 6 gave the limit for different strengths.

The use of bent-up bars was made more restrictive in CP 110, since little evidence existed of their suitability without accompanying links. More emphasis was placed on the bursting forces inside bends of reinforcement and consequently the bends in such bars were usually of greater than standard radius. This

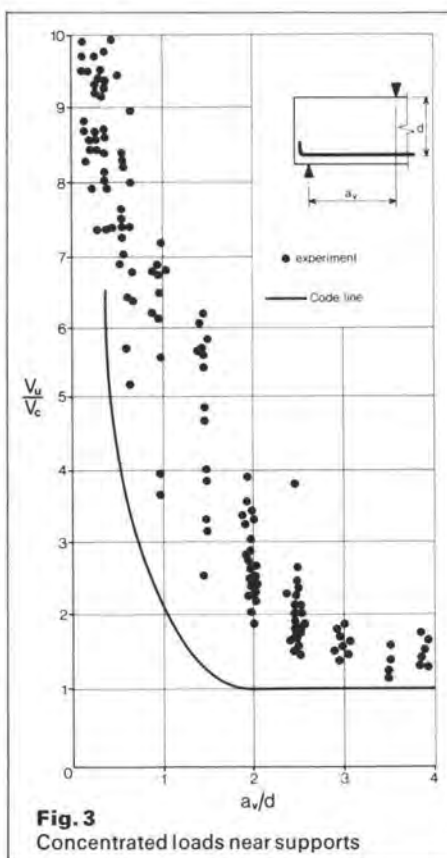

Fig. 3 Concentrated loads near supports

reduced the straight portion of the bar and the bar thus became less effective as shear reinforcement for all but large beams.

Slabs

The shear resistance of slabs to CP 110 followed the treatment for beams. However, one principle to which the code drafters wished strongly to adhere was the use of Table 5 for permissible stresses for all elements. This created an unforeseen problem in the early drafts when considering concentrated loads on slabs, and was of particular importance in the design of flat slabs.

In the early drafts of CP 110 the critical perimeter for punching shear was considered to occur at a distance half the slab depth from the edge of the loaded area following CP 114. The effect of the much-reduced permissible stresses of Table 5 was, of course, to reduce the shear capacity of the slab. Practical examples carried out by the author for Ove Arup and Partners showed that this would dramatically increase the depth required, compared with the same design to CP 114. This was one of a number of occasions when the argument was put forward: 'Why should such a dramatic reduction in carrying capacity be imposed when there had been no evidence that existing structures were that unsafe?'

This resulted in further study of the test results, from which Regan showed that the natural angle for the punching shear plane was about 20° to the horizontal. This is now recorded in CIRIA Report No. 89¹³. As a result, the critical perimeter was chosen to be 1.5 times the slab depth from the face of the loaded area as shown in Fig. 5. The combination of reduced permissible stress and a larger perimeter still provided a more conservative result than CP 114, but it was accepted by the code committee.

One other factor taken into account for slabs was the effect of scale on the shear capacity. This resulted from research carried out by Leonhardt¹⁴ and Taylor¹⁵. Their tests showed that thinner slabs fail at slightly higher stresses than thicker ones. Accordingly Table 14 was introduced into CP 110 giving an enhancement to the shear resistance of slabs thinner than 250 mm.

Flat slabs

The shear clauses for flat slabs in CP 110 were very different from those in CP 114 due to:

- (a) The adoption of the lower permissible stresses of Table 5, together with a larger shear perimeter
- (b) The further 20% reduction of the permissible shear stresses as explained earlier
- (c) The introduction of a magnification factor for the shear force which was a function of the moment transferred from slab to column. This was the result of work carried out by Regan¹³. He found that the out-of-balance moment created in the slab from moment transfer at internal columns caused a reduction in the shear resistance. The formula first introduced in 1972 for the effective shear force was:

$$V_{\text{eff}} = V + 12.5M/l$$

- where V represented the calculated elastic shear
- M represented the moment transferred from slab to column
- l represented the length of the shorter adjacent span.

It was considered not necessary to apply this magnification factor where the ratio between adjacent spans was less than 1.25.

The attempts at practical use of CP 110 soon made it apparent that for slabs with unequal spans the magnification factor could rise to a value of 3 and over. This led to a very dramatic change in design for such slabs. The 20%

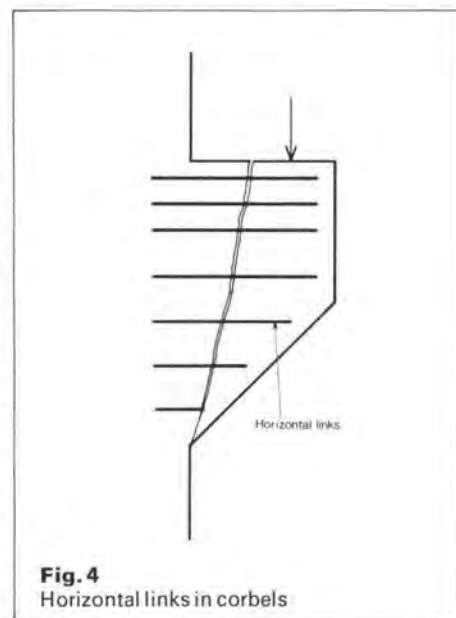

Fig. 4 Horizontal links in corbels

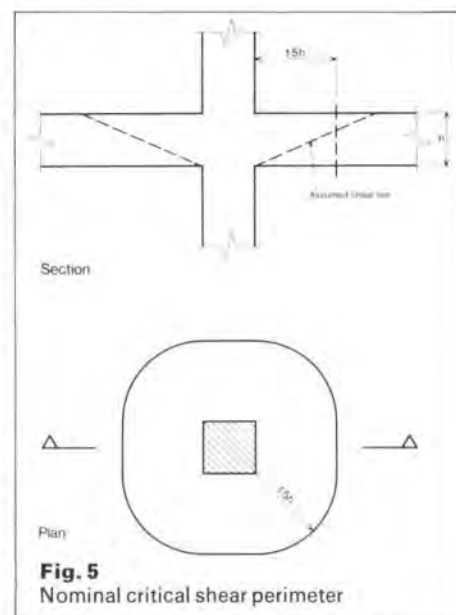

Fig. 5 Nominal critical shear perimeter

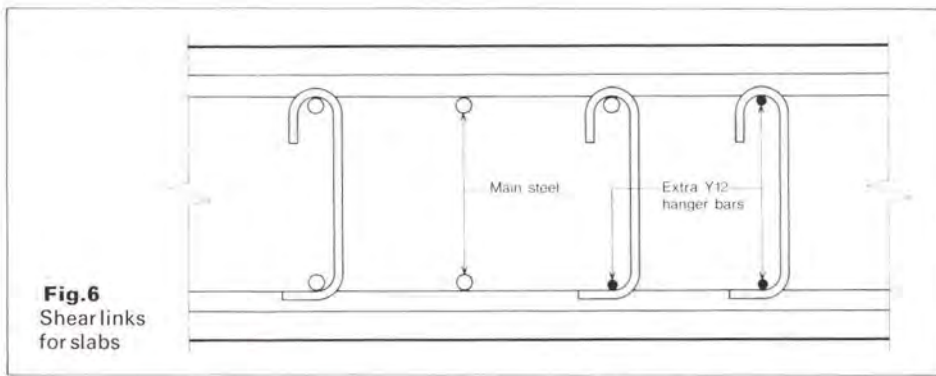

Fig. 6
Shear links for slabs

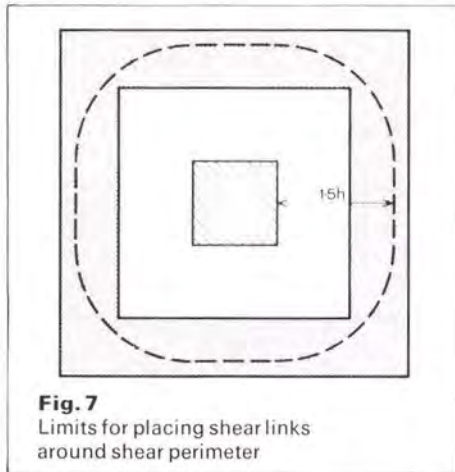

Fig. 7
Limits for placing shear links around shear perimeter

reduction in permissible stresses alone necessitated the use of shear reinforcement, not previously required by *CP 114*, for many new structures. The added effect of moment transfer for internal columns often caused the designed slab depth to be increased. Ove Arup and Partners, in reaction to this, prepared information gained from actual jobs and presented it to the code committee in 1974. This helped to stimulate the changes brought about in 1976.

Practising engineers found the use of the new clauses of *CP 110* much more complicated than those of *CP 114* and often the slabs in question required shear reinforcement. The method of placing such reinforcement required new techniques and detailing. Although the handbook⁵ to *CP 110* gave recommendations for this, they were considered by some to be clumsy and difficult to place. Ove Arup and Partners adopted a method using single leg links as shown in Fig. 6. Although this often involved a large number of links, it did not present any major fixing problems.

The method given in *CP 110* for the amount of reinforcement required for shear was based on the concept of checking successive perimeters 0.75h from the face of the column. The nominal critical perimeter was at 1.5h and if this required reinforcement, then the same amount was also required on the inner perimeter. Outer perimeters were then checked until shear reinforcement was not required.

It was unfortunate that these clauses led to a number of misunderstandings. The fact that shear perimeters had round corners often led engineers to insist that the shear reinforcement be placed along this line. Fixing this reinforcement became awkward when all the other reinforcement was detailed orthogonally. Each perimeter checked represented a failure plane for which reinforcement placed anywhere in the middle two thirds would be effective as shown in Fig. 7.

Corbels, half joints and nibs

CP 110 gave much more attention to the design and detailing of corbels, half joints and nibs than previous British codes. Although it suggested that the design should be based on a simple strut and tie system, the depth of

corbel at the face of support was determined by the new shear clauses for concentrated loads near supports. This recognized the increase of shear resistance as the failure plane became steep. Work by Somerville¹⁰ summarized the approach adopted by *CP 110* for corbel design and emphasized the importance of horizontal links.

For half joints the method for detailing followed proposals by Reynolds²³. However, although analytically preferred, the detail given in *CP 110* as shown in Fig. 8 met with considerable criticism because of the difficulty in fixing the reinforcement. The alternative also shown was more traditional, worked nearly as well and was easier to construct. It should be noted that any tendency to horizontal movements can drastically reduce the strength of such a joint. The provision of bar 'a' shown in Fig. 8 is vital in such circumstances.

Amendments to shear clauses in 1976

As a result of criticism from the industry the code committee, CSB 39 as it had now become, reconsidered the shear clauses for slabs. Although it was recognized that the subject of flat slabs required much closer scrutiny the following improvements were made:

(a) Table 14, Enhancement of Permissible Shear for Thin Slabs, was extended and increased. It now applied to slab thicknesses less than 300 mm and rose to a value of 1.5 for slabs 150 mm thick or less. This represented an 8% increase in permissible stress as compared with the 1972 version, but was still much more conservative than *CP 114*.

(b) Where shear reinforcement was required under concentrated loads, the allowance for the concrete shear resistance was altered to include the enhancement factor of Table 14.

(c) Two changes were made for flat slabs. The first was to alter the 20% reduction of permissible stress to a factor of 1.25 on the applied shear force. The explanation for this factor given in the new clause was to allow for non-symmetrical distribution of shear round the column. Although this was not the original intention for the factor it certainly made more logical sense to the user. The new clause was also worded so that this factor did not have to be used in addition to the magnification factor dependent on moment transfer, but only if it were greater.

The second change referred to the moment transfer formula. The definition of l was altered to represent the longer instead of the shorter of the two adjacent spans. The justification for this change was based on the fact that the formula was based on punching shear tests with equal spans. A conservative approach for unequal spans had originally been chosen.

Reinforcement detailing of nibs was critical for their strength. Research by Clarke¹² indicated that the most effective detailing was as shown in Fig. 9a. However, commonly used details were as shown in Figs. 9b and c. The revisions to *CP 110* in 1976 included an increase of shear resistance by a factor $2d/a_v$ as Clarke recommended.

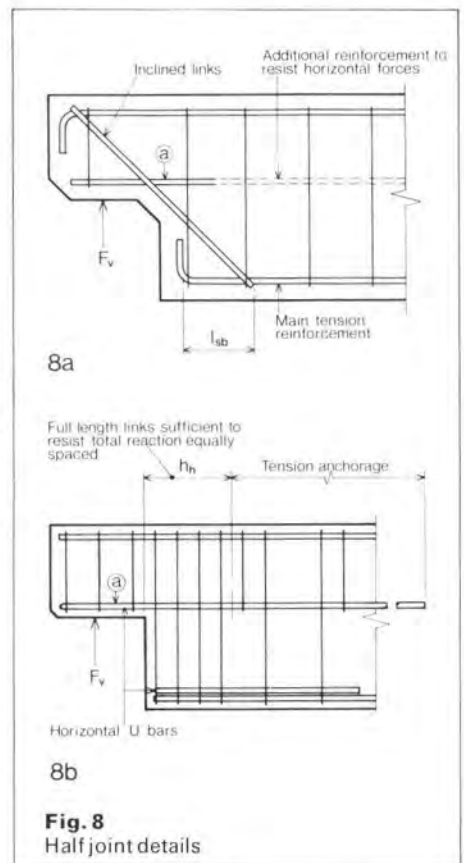

8a

8b

Fig. 8
Half joint details

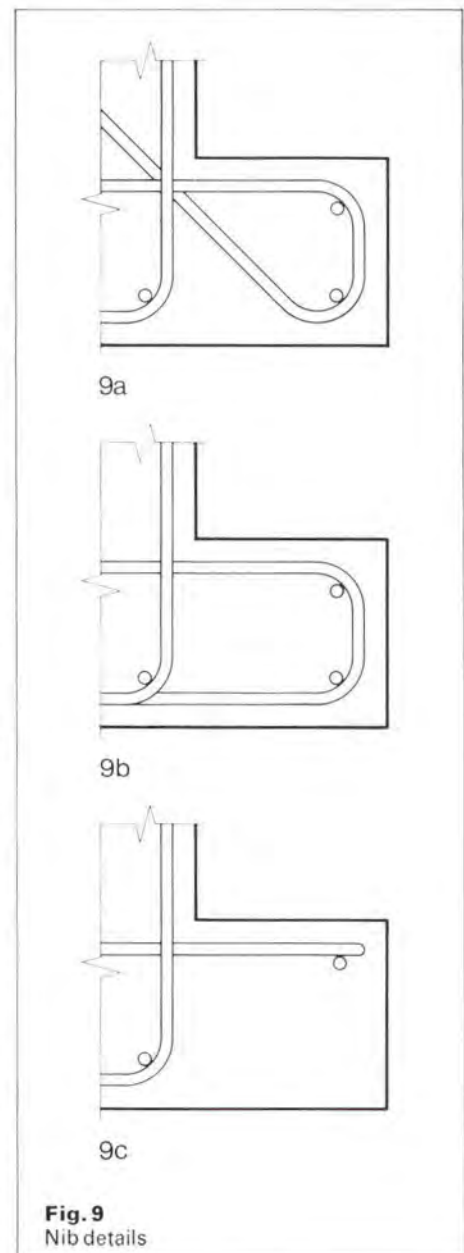

9a

9b

9c

Fig. 9
Nib details

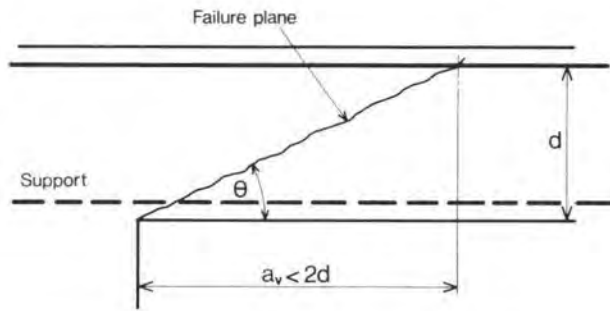

Fig. 10
Failure planes
in beams
close to a support

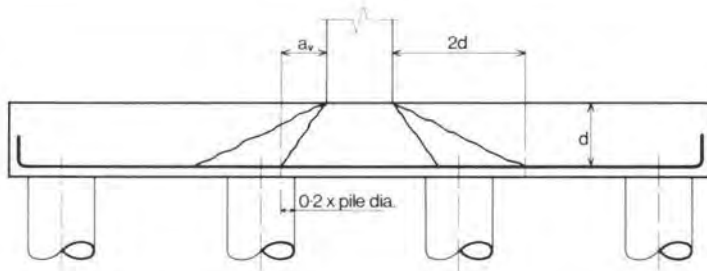

Fig. 11
Failure planes
for pile caps

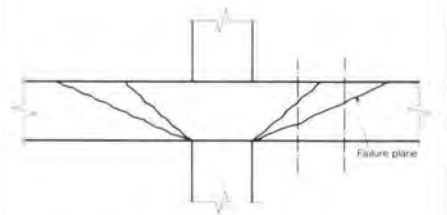
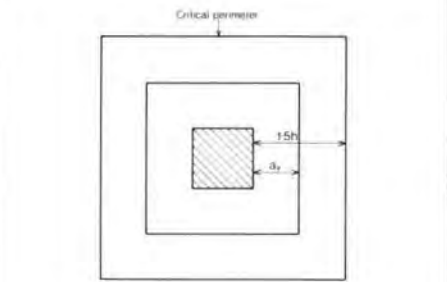

Fig. 12
Failure planes for
concentrated loads on slabs

CP 110: 1981 draft for comment

A number of further changes were made to the shear clauses in this draft. They included the following:

(1) A new policy throughout the code was to give equations for design permissible stresses showing how the material safety factors had been incorporated. The old Table 5 was now accompanied by the equation for permissible design shear stress v_c :

$$v_c = \frac{0.27}{\gamma_m} \sqrt[3]{\frac{100A_{s\text{prov}}}{b_w d} \cdot f_{cu}}$$

where γ_m is taken as 1.25 and f_{cu} must not exceed 40.

The justification for the value of γ_m was based on calibration exercises carried out at the C & CA.

The formula should provide engineers with useful information in circumstances outside the normal design problem, e.g. determining the safety factor for an existing structure.

(2) A further increase was given to the shear stress enhancement factor, ξ , for thin slabs. This was now applicable for slabs less than 500 mm thick and increased to 1.5 for slabs 100 mm thick.

(3) Instead of treating concentrated loads close to the supports as a special condition for the enhancement of shear strength, a more logical approach was given. This considered the enhancement of shear strength of sections close to supports for any type of loading. The failure plane was defined as extending from the face of support to the section considered as shown in Fig. 10. The same enhancement factor of $2d/a_v$ applied, but it could now be used for different purposes such as checking the amount of shear reinforcement required close to a support for any sort of loading conditions.

This new approach made considerable difference to the way pile caps were checked for shear. Critical failure planes were chosen according to the position of piles as shown in Fig. 11. In order to allow for inaccuracies of placing the piles, the failure plane was assumed to pass 1/5 of the pile size beyond the inner face as shown. It was now apparent that more than one failure plane should be checked.

(4) For slabs, the approach adopted for concentrated loads on beams was followed

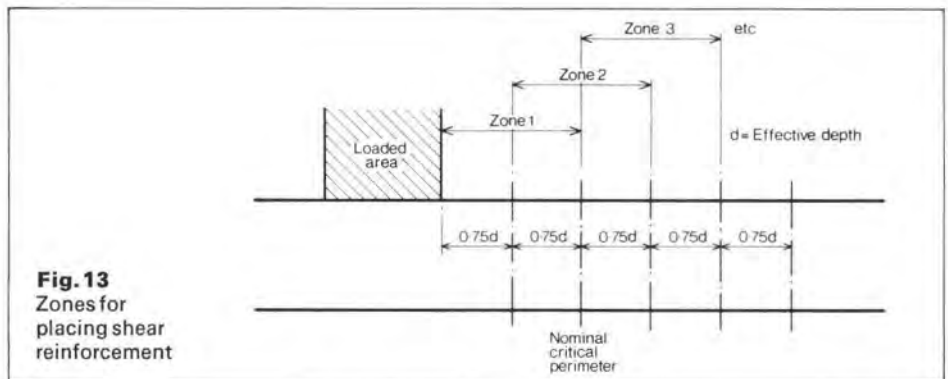

Fig. 13
Zones for
placing shear
reinforcement

with one or two differences. The critical perimeter chosen for concentrated loads on slabs was changed from 1.5 times the depth to 1.5 times the effective depth of slab to be more in line with the other shear clauses. Any perimeter checked inside this was accompanied by an enhanced shear resistance of $1.5d/a_v$ as shown in Fig. 12. This was not directly compatible with beams since the distance $2d$ for beams represents the top end of the failure plane, whereas $1.5d$ for slabs represents the position of perimeter about $\frac{1}{5}$ up the failure plane.

The method of calculating for shear reinforcement in the new draft assumed rectangular perimeters. Although this might not be strictly correct it simplified the calculations and details. Zones were defined to indicate where shear reinforcement might be placed if it was required, as shown in Fig. 13.

The new clauses removed the need to add shear reinforcement inside a perimeter $0.75d$ from the loaded face. This in effect halved the amount of shear reinforcement required previously (unless outer perimeters also required shear reinforcement).

(5) The provisions for flat slabs were altered considerably due to proposals from Regan¹³ and Long^{17,18}. The magnification factor due to moment transfer from slab to column was altered so that it was no longer a function of either of the adjacent spans but depended on the column dimension perpendicular to the spanning direction. The effective applied shear stress, v , became:

$$v = \frac{V}{ud} \left(1 + \frac{1.5M}{V_x}\right)$$

where V was the elastic applied shear force
 M was the moment transfer from slab to column
 x was the length of the side of shear perimeter parallel to the axis of bending
 u was the length of shear perimeter considered.

The justification for this change was that for flexible structures, such as normal flat slabs, the column size had more effect than the slab span on shear capacity. For stiffer structures the span had more effect.

The clauses in the new draft of *CP110* were not identical to those of the *CEB-FIP Model Code*¹⁹ but there were strong similarities. Considerable reference was made to it by the working parties during the drafting of the new clauses.

Although *CP 110* was presented very differently to the American Building Code, *ACI 318-77*²⁰, it produced similar design solutions.

Conclusion

Shear clauses of *CP 110* have been under continuous scrutiny since they were first drafted, both in the practising and research fields of the industry. Though not perfect, they represent a much closer understanding of the behaviour of reinforced concrete than *CP 114*.

Acknowledgement

The author is grateful for the help and advice in preparing this paper given to him by Poul Beckmann of Ove Arup and Partners and Paul Regan of the Polytechnic of Central London.

For references see next page.

References

- (1) BRITISH STANDARDS INSTITUTION. CP 110: Part 1: 1972. The structural use of concrete. BSI, 1972.
- (2) BRITISH STANDARDS INSTITUTION. CP 110: Part 1: 1981. The structural use of concrete. Draft for comment.
- (3) BRITISH STANDARDS INSTITUTION. CP 114: 1969 Part 2. Metric units. The structural use of reinforced concrete in buildings. BSI, 1969.
- (4) BRITISH STANDARDS INSTITUTION. CP 116: 1969 Part 2. Metric units. The structural use of precast concrete. BSI, 1969.
- (5) INSTITUTION OF STRUCTURAL ENGINEERS. Shear strength of reinforced concrete beams, a report by the Shear Study Group. ISE, 1969.
- (6) HANDBOOK ON THE UNIFIED CODE FOR STRUCTURAL CONCRETE. Cement and Concrete Association, 1972.
- (7) TAYLOR, H. P. J. An investigation of the dowel forces carried by the tensile steel in reinforced concrete beams. TR 42.431. C & CA, 1969.
- (8) TAYLOR, H. P. J. Further tests to determine shear stresses in reinforced concrete beams. TR 42.438. C & CA, 1970.
- (9) TAYLOR, H. P. J. Investigation of the forces carried across cracks in reinforced concrete beams in shear by interlock of aggregate. TR 42.447. C & CA, 1970.
- (10) SOMERVILLE, G. The behaviour and design of reinforced concrete corbels. TR 42.472. C & CA, 1972.
- (11) CLARKE, J. L. Behaviour and design of pile caps with four piles. TR 42.489. C & CA, 1973.
- (12) CLARKE, J. L. Behaviour and design of small nibs. TR 42.512. C & CA, 1976.
- (13) REGAN, P. E. Behaviour of reinforced concrete flat slabs. Report 89. CIRIA, 1981.
- (14) LEONHARDT, F. and WALTHER, R. The Stuttgart shear tests 1961. Publication 61.111. C & CA, 1964.
- (15) TAYLOR, H. P. J. The shear strength of large beams. *Proceedings of the American Society of Civil Engineers Structural Division*, 98 (ST11), pp. 2473-2490, 1972.
- (16) TAYLOR, H. P. J. Shear at points of curtailment. *Concrete*, 7 (2), pp. 30-31, 1972.
- (17) LONG, A. E. Punching failure of slabs – transfer of moment and shear. *Proceedings of the American Society of Civil Engineers, Structural Division*, 99 (ST4) pp. 665-685, 1973.
- (18) LONG, A. E., KIRK, D. W. and CLELAND, D. J. Moment transfer and the ultimate capacity of slab column structures. *The Structural Engineer*, 56A (4), pp. 95-102, 1978.
- (19) COMITE EUROPEEN DU BETON. CEB-FIB model code for concrete structures. *Bulletin d'Information N125E*, Paris, 1978.
- (20) AMERICAN CONCRETE INSTITUTE. *ACI 318-77*, Building code requirements for concrete. ACI, 1977.
- (21) KRIZ, L. B. and RATHS, C. H. Connections in precast concrete structures – strength of corbels. *Journal of Prestressed Concrete Institute*, 10 (1), pp. 16-61, 1965.
- (22) CLARKE, J. L. and TAYLOR, H. P. J. Web crushing – a review of research. TR 42.509. C & CA, 1975.
- (23) REYNOLDS, G. C. The strength of half joints in reinforced concrete beams. TR 42.415. C & CA, 1969.

Structural causes of non-structural defects

Poul Beckmann

Inherent structural behaviour

The majority of problems with non-structural building elements are probably caused by bad workmanship, closely followed by bad detail design and/or specification of unsuitable materials.

There are however many non-structural defects which can be traced to the designer's neglect of basic structural behaviour.

Basic structural behaviour can in this context be expressed thus:

No beam, slab or plate carries load without deflecting.

No column, wall or strut carries load without shortening.

No footing or pile carries load without settling.

No component changes temperature without changing dimensions.

No component changes moisture content without changing dimensions.

No change of dimension is restrained without force.

The first three types of movement generally have two components: an instantaneous (or nearly instantaneous) response to the application of load and a residual, gradually stabilizing, long-term deformation under sustained (but not increasing) load. This latter phenomenon, called 'creep' is often related to loss of moisture, e.g. in concrete, but not always, e.g. relaxation of steel wires. Temperature and moisture movements occur in two phases. First there is the once-and-for-all transition from conditions during construction to conditions in the finished building and then there are the never-ending 22 fluctuations imposed by the environment.

It must, however, be remembered that the initial transition may take longer than the period of construction. Heavy structural members of dense concrete may take many years to reach moisture equilibrium with the atmosphere and will, during that time, continue to shrink and creep; or in other words: beams will continue to deflect and columns and walls will go on shortening, albeit at a decreasing rate.

The effects of 'improved' technology

It is sometimes said that building problems arising from structural movements have been aggravated by modern technology. There is some truth in this.

Advances in materials technology have made it possible to produce materials of far greater strength than those used for construction 50 years ago, but the inherent stiffness of a material does *not* increase in proportion to the strength. The yield strengths of commonly available steels have been raised from about 225 N/mm² (32,500 lb./in.²) to 450 N/mm² (65,000 lb./in.²), but the stiffness, as measured by the modulus of elasticity (Young's modulus) remains stubbornly at 200,000 N/mm² (29,000,000 lb./in.²). The load-carrying capacity of, say, a steel beam of given span and section is proportional to the strength of the steel. The deflection of the same beam is proportional to the load it carries and inversely proportional to its modulus of elasticity. Thus if we double the strength of the steel and succumb to the temptation to double the load on the same beam we get twice the deflection. For concrete the situation is not much better: the modulus of elasticity increases with the square root of the strength, so that for a given member, doubling the strength of the concrete might enable twice the load to be carried at 40-odd % greater deflection initially; but the strength gain will have been achieved by using more cement and this will lead to increased shrinkage and creep which in turn will cause additional long-term deflections.

The only way of reducing these deflections is to use a deeper beam, which often is what the use of stronger materials is intended to avoid!

Modern construction techniques also contribute to the problems:

Old buildings were usually constructed from materials of relatively low strength and the stresses in their structural parts were usually low so that the load-induced deformations in the superstructure were small. They were built slowly and the mortar in the masonry was slow in hardening and thus permitted settlement to occur without causing alarming cracks.

Modern buildings have structures of relatively strong materials, and economic exploitation of the strengths generally results in load-induced deformations which are not negligible. The financial advantage of short construction periods have led to the use of fast-setting mortars and plasters which in response to structural movement are liable to crack rather than give, and rapid completion allows less time for settlement and moisture movement before the building is occupied.

The communications gap and its consequences

There is nothing new in what has been stated so far, and engineers are taught about deflections. The trouble is that the engineer is often so busy making calculations to prove to the local authority that the paper design conforms to the code of practice, that he forgets that the deflections permitted by the code may not be familiar knowledge to the architect. He consequently forgets to tell the architect about these deflections and the other structural movements that are likely to happen and the architect as a result omits to make provision for structural movement when detailing the finishes. (It has to be said, unfortunately, that there are also some architects, who, if they were told, would not want to know).

The results are only too well-known: Inadequate provision for structural movement invariably creates problems with adjacent non-structural elements.

It follows that when defects in non-structural elements are caused by the behaviour of the structure, simple repairs will not be satisfactory unless the cause can be proved to be no longer active. If this is not the case it

will be necessary to carry out remedial works which will allow the structure to undergo its natural movements without causing damage or distress to the non-structural elements. What can NOT be done is to eliminate the movements.

For example: If cracking of blockwork partitions can be shown to be solely due to shrinkage and creep deflection of the reinforced concrete floor structure, then after a period of, say, five years, simple plaster repairs have a fair chance of lasting success. If, however, the cracking is caused, or aggravated, by seasonal thermal movement of the roof structure, the partitions have to be separated from the roof, but often in such a way as to still receive lateral restraint from it!

The significance of observed movements

Before specifying remedial works, one should however assess whether the amount of movement observed can be judged to be part of 'normal structural behaviour' or whether it may signify some serious structural defect caused by faulty design or construction.

There are no ready-made answers to these questions. The design codes state certain limits, but with qualifications which can be interpreted by the design engineer to allow larger deflections if he sees fit to do so.

CP110: 1972 'The structural use of concrete' cl.2.2.3.1. states for instance:

'The final deflection . . . should not, *in general*, exceed span/250.' *BS449: 1965* states 'The maximum deflection due to loads *other than* the weight of structural floors, or roof, steelwork and casing shall not exceed 1/360 of the span.'

In the case of *CP110* the final deflection is assumed to include effects of temperature, creep and shrinkage, but *not* the possible bedding-in of the formwork props which may add 5-10mm ($\frac{1}{4}$ in. - $\frac{3}{8}$ in.) to the observed midspan sag. *BS449* does not limit deflection due to the own weight of the structure and hence provides no datum for comparison with observed, total, deflections. Neither document mentions shortening of columns or stanchions.

As a rough guide it could be said that it would be prudent to call for a structural appraisal by an engineer, if measured deflections approach or exceed 1/150 of the span, even if nothing else untoward has been observed, and similarly if there are indications that columns have shortened more than 3 mm ($\frac{1}{8}$ in.) in a normal 2.5-3.0 m (8ft.-10ft.) storey height.

The significance of the widths of cracks

With regard to the widths of cracks which should prompt the involvement of an engineer, the position is equally vague. A note of warning must however be sounded against uncritical adoption of the classification table given in BRE Current Paper *CP61/78*.

The figures are only acceptable if

- the cracking is *not* indicative of, or coincident with, inadequate tying together of the building,
- The movement has attained its maximum extent, does not show significant seasonal variations, and can be shown to be due to a cause which is no longer active.

Neglect of (a) will leave the client with a building of inadequate structural integrity, liable to suffer disproportionate damage as a result of relatively minor accidental overloads. Neglect of (b) will result in reappearance of cracks after completion of repairs.

Whilst the structural integrity can usually be

ascertained, 'instantly', by inspection (even if it may require removal of some finishes), it may require measurements, sometimes over a very long period, to prove or disprove ongoing movement and gauge its significance.

(Certain clay soils, such as that at Basildon in Essex, undergo very substantial moisture movements in their upper 3-4 m following the 11-year cycles of alternating very wet and rather dry summers, corresponding to the sun-spot cycles. In such a case, mere observation of structural movement over a period of 2-3 years corresponding to a maximum or a minimum could lead to a mistaken conclusion that movement had ceased for good.)

The two most effective types of measurements are: crack width variation measurements and precise levelling. The necessary accuracy is not too difficult to achieve and instruments and measuring points are fairly robust and simple to use, whereas plumb bobs are slow and laborious and electronics, such as strain gauges, require expensive 'black boxes' and vulnerable wires.

A word of warning about level measurements: It is fairly easy to measure relative vertical movement and this is all that matters when considering superstructure damage. It is, however, sometimes very difficult to ascertain what is going up and what is going down, without installing very expensive benchmarks, fixed deep into stable strata, and when it comes to decide on remedial works, the difference could be crucial; settlement *might* be cured by underpinning the part that appears to go down—heave definitely can NOT.

Examples of brickwork defects due to normal behaviour of reinforced concrete frames

Column shortening will pinch brickwork unless a horizontal compression joint is left at the top of each storey height. This joint means that the brickwork will not be adequately held against windforces unless special provisions are made.

When a continuous full height brick face is created by letting the brickwork overhang the supporting boot-lintel/slab edge and covering this with slip tiles, the cumulative effect of *normal* inaccuracies of construction are such that attempts at making the brick face true to plumb and line will result in inadequate bearing for the full bricks.

Wire ties, cast into concrete members, to be bent out and bedded into the brickwork joints, are very often never seen again.

When, due to frame inaccuracies, cavity ties have to span abnormally wide cavities, they need to be extra long, which they normally aren't, so they don't.

If the frame has a movement joint and the external wall hasn't, something has to give and it does!

Concrete creep and brick 'swelling' come to an end, but temperature movement (esp. of 'black' bricks) go on for ever, and will in due course create pinching if creep and swelling have closed the compression joints.

Example of partition cracking caused by normal deflections of the structure

Somebody, somewhere, had some offices on the first floor of a two-storey building.

An architect had drawn the plans and elevations. A consulting engineer had designed the structure.

The roof structure consisted of steel beams spanning right across the building between peripheral columns, whilst the first floor was a coffered slab supported on a central row of columns as well as on the peripheral columns.

Study of the available information indicated that the architect had shown the thickness

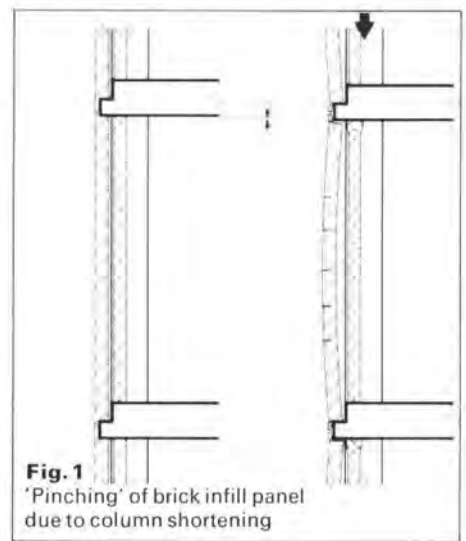

Fig. 1
'Pinching' of brick infill panel due to column shortening

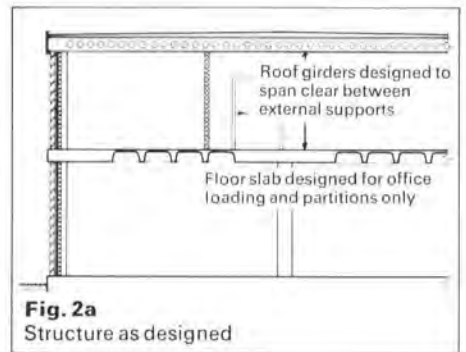

Fig. 2a
Structure as designed

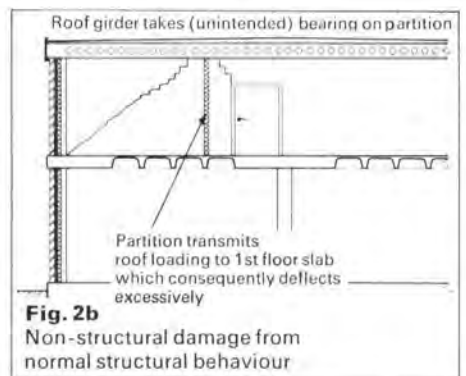

Fig. 2b
Non-structural damage from normal structural behaviour

and type of partitions on his plan, and the consulting engineer had designed the first floor slab to carry an equivalent, uniformly distributed load in addition to the other finishes and the live load. He had not been asked to provide any lateral restraint to the tops of the partitions and the architect had not drawn or specified any means of bracing the top of the block walls. There was no reference to the deflection of the roof beams on the engineer's drawing or anywhere else.

The builder, in the absence of any instructions, pinned the blockwalls to the soffits of the roof beams, wherever he could, so as to provide at least some stability.

The roof beams, instead of spanning clear across the width of the building were, by the pinning up process, given intermediate support on the partitions; the partitions transferred roof load on the first floor slab which was not designed for it; the first floor slab deflected too much and the partitions cracked badly.

A trivial serviceability failure, on the face of it, but one which has caused the building user much inconvenience as a consequence of the necessary remedial works. It could have been avoided by better communication between the architect, the engineer and the builder, assuming that the engineer would have become aware of the way the roof beams were going to behave if the block partitions were built hard up under them.

